

900/ 800 CLASS/ 2250WOG/ PN 155
 SIZE: 1/4"-6" (std.)



SPECIFICATION

- * Body & end caps quality investment casting
- * Valve construction & thickness follow ANSIB16.34
- * Full bore & Std. bore design
- * with ISO 5211 direct mounting pad
- * Adjustable stem packing
- * Available in stainless steel or carbon steel
- * Blow-out proof stem design
- * 100% air tested under water at 80-100 psi
- * Working pressure:
 TFM seat: 1/4"~2", 2160 psi
 DELRIN/ PEEK seat: 2-1/2"~4" & 6" (std.), 2000 psi
- * Temperature range: see Pressure/Temperature table
- * with locking function
- * End type: threaded/ socket weld/ butt weld

OPTION

- * Fire safe design (with SS housing)
- * Spring return handle (dead man handle)
- * Steam jacket
- * V-ball for control valve (ball valve type)
- * Automation application
- * Cryogenic bonnet
- * Fugitive emission bonnet
- * PTFE/ PFA coating (40-70 um)
- * Hastalloy C/ Super duplex/ Alloy 20/ Monel

TypeS35, 3-piece high performance ball valve with ISO direct mounting pad is designed for the high pressure industrial pipe line in full port product. To compare the economic valve in the market, we make valve structure & wall thickness totally follow ASME B16.34 standard. The exact structure make safe in the high performance application.

Super Teflon/ TFM1600 are the standard soft material and suitable for 2000 psi pressure rating from 1/4" to 2". For 2-1/2" to 4" full bore & 6" std. bore, 2000 psi rating, seat was required to be DELRIN (POM) or PEEK.

S35 high pressure valve is with complete size range on 1/4" to 4" full bore (DN08-DN100) and 6" reduced bore (DN150). V-ball for ball valve type control valve are available for 15°, 60°, or 90° for different flow rate requirement.

S35 high performance 3-piece ball valve can be with fire safe design with SS seat housing designed follow API607 Edition 4.

The standard bare stem type is well designed for mounting actuator directly with very low torque value.

We offer pneumatic/ electric actuator and limit switch box/ solenoid valve/ modulating controller....assembling without further charge.

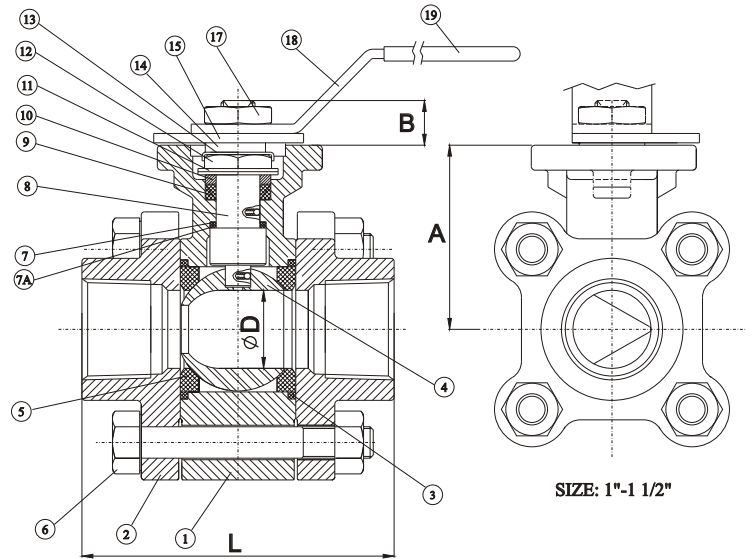

SIZE: 1"-1 1/2"

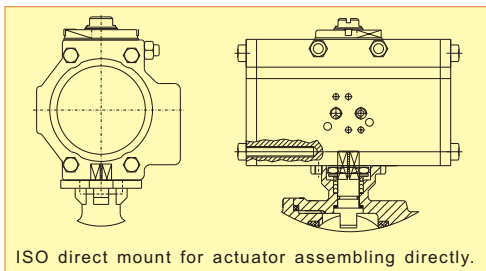
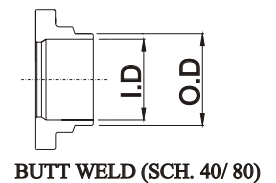
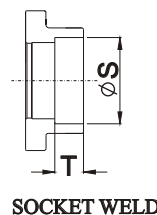

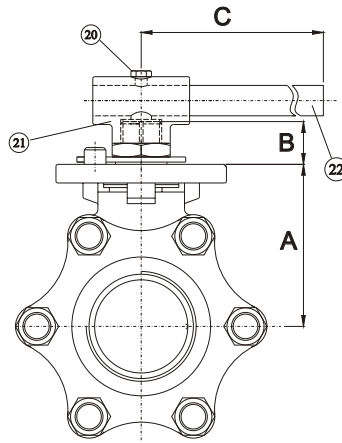
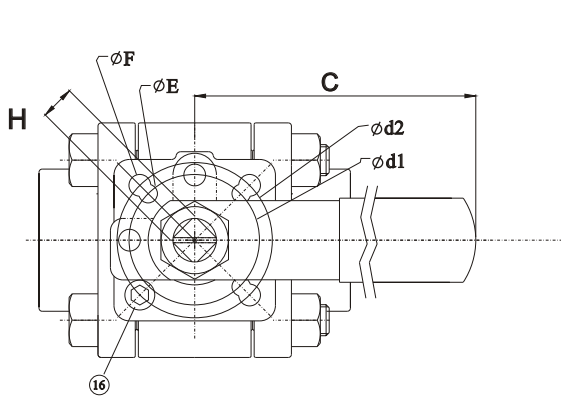

SIZE: 2"

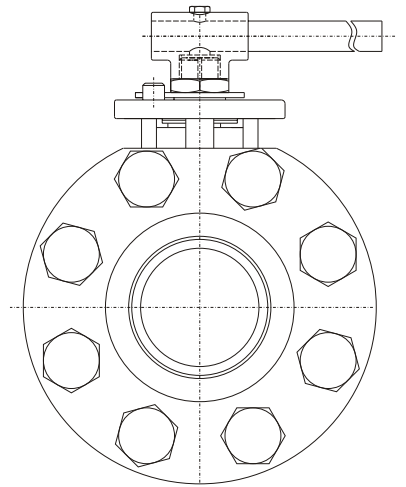

SIZE: 2 1/2"-3"

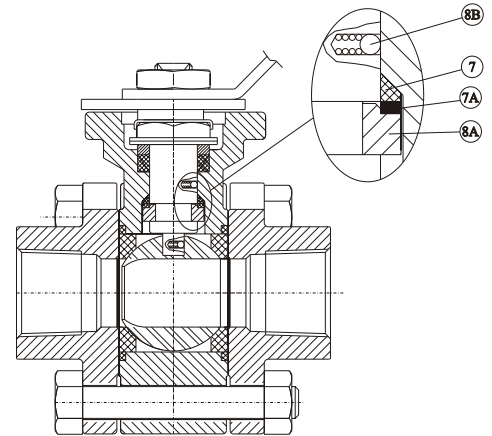

SIZE: 1/4"-3/4"

MATERIALS LIST

ITEM	PART NAME	MATERIALS
1	BODY	CF8M
2	END CAP	CF8M
3	GASKET(BODY)	TFM
4	BALL	SS 316
5	BALL SEATS	TFM/ DELRIN/ PEEK
6	BOLTS	SS 304
7	THRUST WASHER	TFM
7A	THRUST WASHER	PEEK
8	STEM	SS 316
8A	HALF SPLIT RING	SS 316
8B	ANTI-STATIC	SS 316
9	STEM PACKING	TFM
10	GLAND WASHER	SS 304
11	DISK WASHER	SS 301
12	STEM NUT	SS 304
13	NUT STOP	SS 304
14	SPACE WASHER	SS 304
15	PLATER	SS 304
16	STOP PIN	SS 304
17	HANDLE NUT	SS 304
18	HANDLE	SS 304
19	HANDLE COVER	PLASTIC
20	SET BOLT	SS 304
21	LEVER HEAD	CF 8
22	LEVER	STEEL PIPE

MAX. OPERATING PRESSURE

Body Rating (Non-Shock)

VALVE SIZE	MAX. PRESSURE RATING
1/4"~1/2"	UP TO 5000 psi
3/4" & 1"	UP TO 4500 psi
1-1/4" & 1-1/2"	UP TO 4000 psi
2"	UP TO 3000 psi

DIMENSIONS (mm)

SIZE	A	B	C	D	d1	d2	E	F	H	L	SW		BW(40#)		BW(80#)	
											S	T	OD	ID	OD	ID
1/4"	46	9	130	11	6.0	6.0	36	42	9	66.5	14.2	11.1	14.0	9.2	14.0	7.5
3/8"	46	9	130	12.5	6.0	6.0	36	42	9	66.5	17.5	11.1	17.0	12.7	17.0	10.8
1/2"	48	9	130	15	6.0	6.0	36	42	9	70	21.8	12.7	21.3	15.9	21.3	13.8
3/4"	53	12	155	20	6.0	6.0	42	50	11	92	27.1	14.3	26.7	20.6	26.7	18.9
1"	59	12	155	25	6.0	7.0	42	50	11	105	33.8	15.9	33.3	26.6	33.3	24.3
1-1/4"	62	14.5	205	32	7.0	9.2	50	70	14	111	42.5	17.5	42.2	35.1	42.2	32.5
1-1/2"	70	14.5	205	38	7.0	9.2	50	70	14	124	48.7	18.3	48.5	40.5	48.5	38.1
2"	90	19	300	50	9.2	11.4	70	102	17	150	61.1	21.3	60.5	52.4	60.5	49.3
2-1/2"	105	18	350	63.5	9.2	11.4	70	102	17	165	73.9	22.2	73.2	62.7	73.2	59.0
3"	119	25	400	78	11.4	13.5	102	125	22	195	89.9	25.4	89.2	78.0	89.2	73.7

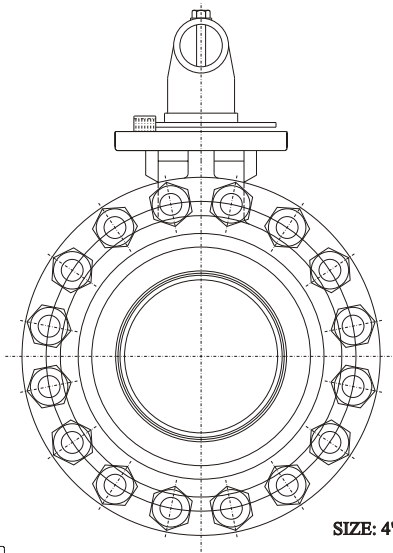

SIZE: 4" & 6" (std.)

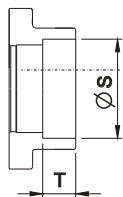

SOCKET WELD

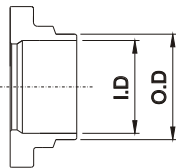

BUTT WELD

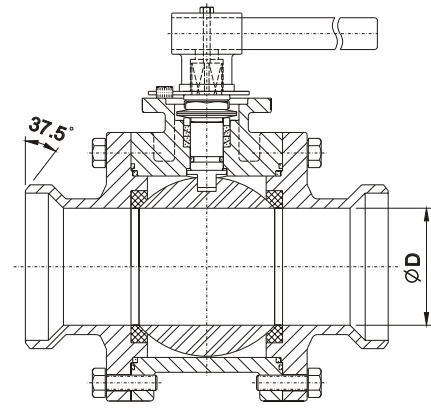

SIZE: 6"
Standard Port Buttweld

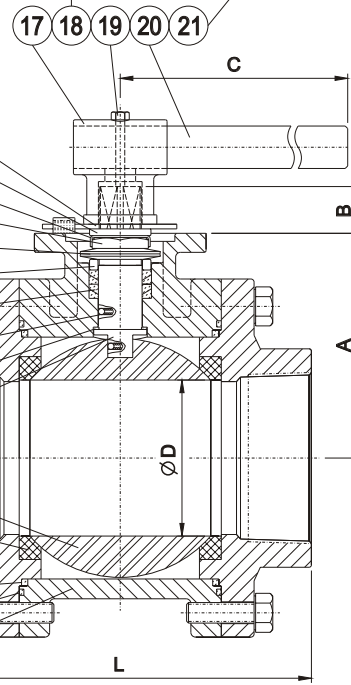
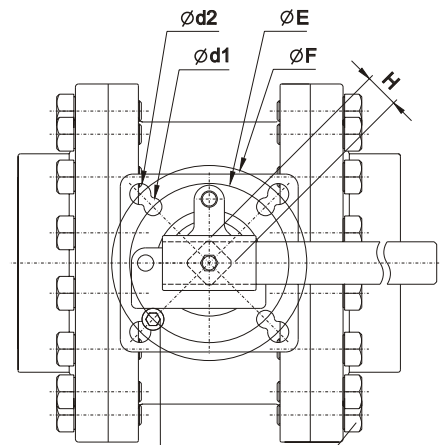

MATERIALS LIST

ITEM	PART NAME	MATERIALS
1	BODY	CF8M
2	GASKET (BIG)	TFM
3	GASKET (SMALL)	TFM
4	END CAP	CF8M
5	BALL SEATS	TFM/ DELRIN
6	BALL	SS 316
7	STEM	17-4 PH
8	THRUST WASHER	PEEK
9	ANTI-STATIC	SS 316
10	STEM PACKING	TFM
11	GLAND WASHER	SS 304
12	DISK WASHER	SS 301
13	STEM NUT	SS 304
14	NUT STOP	SS 304
15	SPACE WASHER	SS 304
16	PLATER	SS 304
17	LEVER HEAD	CF8
18	STOP PIN	SS 304
19	SET BOLT	SS 304
20	LEVER	STEEL PIPE
21	BOLTS	SS 304

DIMENSIONS (mm)

SIZE	A	B	C	D	d1	d2	E	F	H	L	SW		BW(40#)		BW(80#)		BW(160#)	
											S	T	OD	ID	OD	ID	OD	ID
4"	144	25	380	99	11.5	13.5	102	125	22	245	115.2	32	114.5	102.2	114.5	97.2	114.5	87.3
6" (std)	144	25	380	99	11.5	13.5	102	125	22	310	-	-	168.3	154	168.3	146.3	168.3	131.7

PRESSURE/ TEMPERATURE

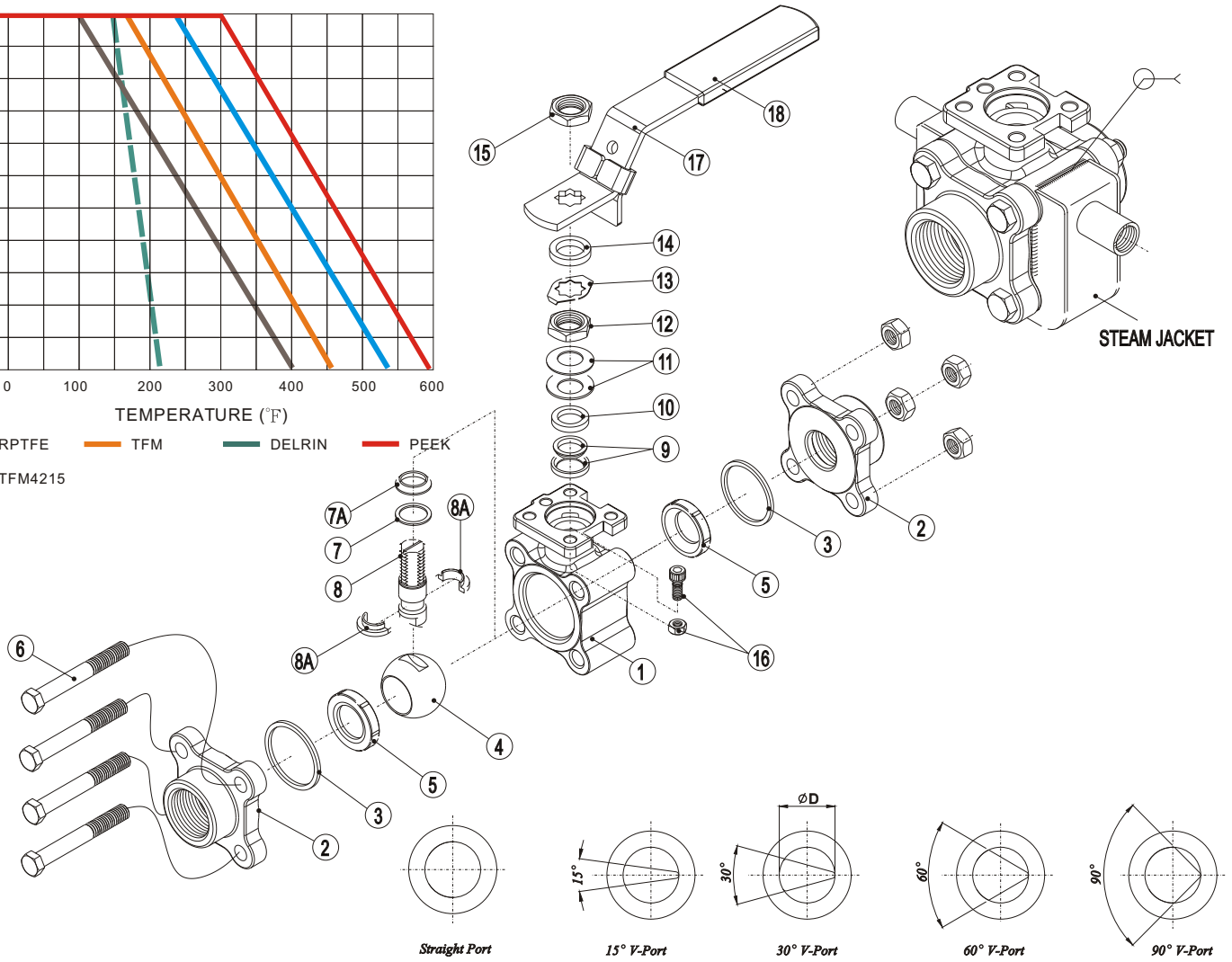
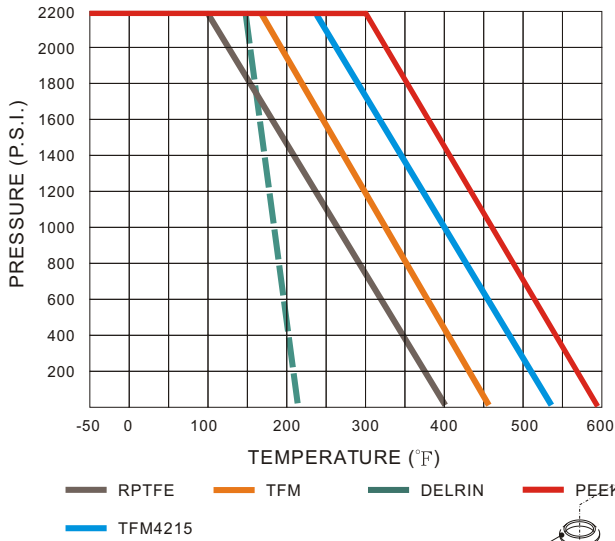

BREAK-TORQUE VALUE (Nm/ at 2000 psi)

SIZE	1/4"	3/8"	1/2"	3/4"	1"	1 1/4"	1 1/2"	2"	2-1/2"	3"	4"
SEAT	TFM	TFM	TFM	TFM	TFM	TFM	TFM	TFM	DELRIN	DELRIN	DELRIN
GREASE	8	8	12	15	18	25	47	83	165	250	380

Note 1: The greases we use including lubricant & anti-seize grease are both SILICONE-FREE.

Note 2: Strongly suggest increasing at least 30%~40% for safety factor for mounting actuator.