

Ref. : VG 3400-03.pas

Rev. : B

Date : 31/08/10

Page : 1/2

KNIFE GATE VALVE WITH DOUBLE ACTING PNEUMATIC ACTUATOR

VG 3400-03

APPLICATION

General use : Pulp production, water, water treatment, waste water, chemical industry (powdery or crystallizing products), wine-producing, pulverized products (cement work, pneumatic transport, stocking).

GENERAL CHARACTERISTICS

Function ON/OFF or regulation.
Wafer threaded mounting ISO PN10.
Unidirectional tightness, direction indication thanks to the arrow on the body.
Small retention zone: the gate is guided in the body and has little clearance.
Gland assembly: packing and O-ring (same material as seat joint) to assure the elasticity and decrease the operating force.
Small head loss.
Possibility to regulate thick fluids the adaptation of a diaphragm ring .

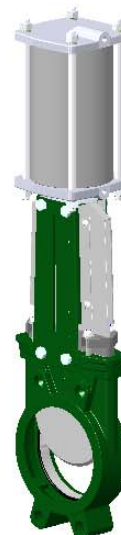

CONSTRUCTION

11	2	Protection plate	Stainless steel 304	DIN : X5CrNi 18-10 ASTM : AISI 304 BS : 304 S15
10	1	O-ring	Nitril	
9**	1	Support ring	Stainless steel 316	DIN : X5CrNiMo18 10 ASTM : A 182 AIS 3 16 BS : 316 S16
8**	1	Gasket	Nitril	
7	1	Packing gland	Aluminium DN50-450 Steel DN500-600	
6	1	Pneumatic actuator	Aluminium	
5*	2	Support plate	Steel + epoxy	
4	1	Stem	Stainless steel 13%Cr	
3	1	Knife gate	X5CrNi 18-10	DIN : X5CrNi 18-10 ASTM : AISI 304 BS : 304 S15
2	2	Packing	PTFE	
1	1	Body	EN-GJL-250	DIN : GG 25 ASTM : A48 class 40B BS : 1452 Grade 250
Pos.	Qty.	Description	Material	

* Pre-shaped parts up to DN 300.

** Missing parts on metal / metal tightness.

DIMENSIONS

DN		A	B	C	D	Ø F	Ø P	H	Ø K	n	Ø M	Weight (kg)
mm	inch											
50	2"	40	240	124	83	1/4"	80	412	125	4	4-M16	7,5
65	2 1/2"	40	265	139	83	1/4"	80	458	145	4	4-M16	7,8
80	3"	50	290	154	83	1/4"	80	502	160	8	4-M16	8,4
100	4"	50	335	174	83	1/4"	100	562	180	8	4-M16	12,5
125	5"	50	373	189	93	1/4"	125	642	210	8	4-M16	16,4
150	6"	60	424	220	93	1/4"	125	718	240	8	4-M20	20,5
200	8"	60	533	275	108	1/4"	160	882	295	8	4-M20	35,8
250	10"	70	625	326	108	1/4"	200	1044	350	12	8-M20	52
300	12"	70	732	380	108	1/4"	200	1164	400	12	8-M20	72
350	14"	96	835	438	290	3/8"	250	1362	460	16	10-M20	129
400	16"	100	945	494	290	3/8"	250	1542	515	16	10-M24	144
450	18"	106	1040	547	290	3/8"	250	1677	565	20	14-M24	177
500	20"	110	1150	613	290	1/2"	382	1839	620	20	14-M24	260
600	24"	110	1354	716	290	1/2"	382	2145	725	20	14-M27	341
700	28"	110	1540	835	320	1/2"	426	2488	840	24	16-M27	556
800	32"	110	1750	972	320	1/2"	426	2798	950	24	16-M30	679
900	36"	110	1990	1041	320	1/2"	538	3162	1050	28	20-M30	840
1000	40"	110	2195	1152	320	1/2"	538	3452	1160	28	20-M33	1053
1200	48"	150	2390	1255	400	1/2"	538	4048	1380	32	22-M36	-

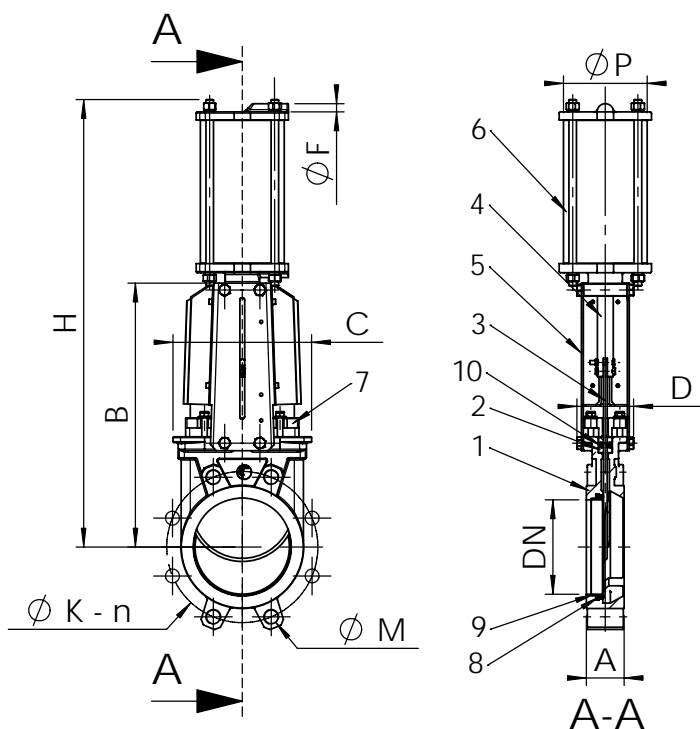

Ref. : VG 3400-03.pas

Rev. : B

Date : 31/08/10

Page : 2/2

KNIFE GATE VALVE WITH DOUBLE ACTING PNEUMATIC ACTUATOR

VG 3400-03

WORKING CONDITIONS

Maximum working pressure : DN 50-250 : 10 bar
DN 300-450 : 7 bar
DN 500-600 : 3 bar
DN 700-1200 : 2 bar

Maximum temperature : -10°C / +80°C

Others materials on request (if marked)	Maximum temperature	
Metal / metal	T max : -10°C / +200°C.	<input type="checkbox"/>
White NBR	T max : -10°C / +80°C.	<input type="checkbox"/>
EPDM	T max : -20°C / +130°C.	<input type="checkbox"/>
Silicone	T max : -20°C / +170°C.	<input type="checkbox"/>
FPM (Type Viton®)	T max : -10°C / +170°C.	<input type="checkbox"/>
PTFE	T max : +4°C / +170°C.	<input type="checkbox"/>
CSM (Type Hypalon®)	T max : +4°C / +80°C.	<input type="checkbox"/>



Standard tightness



Tightness metal/metal

STANDARDS

Manufacture according to the requirements of the European directive 97/23/CE «Equipments under pressure» : category III modulate H. (DN50 - 600)

On request : Product in accordance to european directive "Potentially explosive atmospheres" N° 94/9/EC : ATEX II 2 GD c and ATEX II 3 GD c.

Test procedures are established according to standard EN 12266-1, DIN 3230, BS 5154 and ISO 5208.

Connections according to standard EN 1092-2 and DIN 2501 : ISO PN10.