

## DN25 – DN1000 resp. 1" – 42"

SBP Butterfly Valves are ideally suited for Shut-off, Flow Control and Throttling of corrosive and abrasive process media in either liquid, powdery or gaseous state.

### Modular Design

Valves are available as wafer- or lug-style versions, with bare shaft as per standard. Valves can be delivered as complete units, i.e. with mounted-on locking handles, manual gearboxes or with quarter turn pneumatic actuators double- or single-acting.

The sturdy design bodies are made of cast steel 1.0619 (WCB), coating RAL 5005 signal-blue or stainless steel casting 1.4408 (CF-8M), with resistant liners such as PTFE, PTFE-AS (anti-static), PTFE-T (mod.) or UHMWPE.



### Main Features

- Heavy-duty, compact construction, maintenance-free
- Bubble-tight shut-off throughout the full pressure and temperature range
- Wide selection of high-quality liner and disc materials for economical valve performance
- Unique shaft sealing arrangement assures maintenance-free operation at automated processes and high operating pressures, optimized and reinforced liner shape
- No need of additional flange gaskets due to wide and chambered flange sealing surface
- One-piece disc/shaft for hysteresis-free flow control, with polished sealing surface leading to low torque values
- Flange connections according to DIN PN10/16 resp. ANSI 150lbs, for installation into existing piping systems

**Conformity according to European Pressure Equipment Directive 97/23/EC (PED)**

### Options



**Lug 1.0619** (WCB)  
PTFE/PFA, locking handle



**Lug 1.4408** (CF-8M)  
PTFE-AS/PFA-AS, bare shaft



**Wafer SS316L** (1.4435)  
PTFE/PFA, pneum. actuator



**Wafer 1.0619** (WCB)  
PTFE/PFA, pneum. actuator  
and E/P positioner

### Operating Conditions

- Temperature range from  $-40^{\circ}\text{C}$  ( $-40^{\circ}\text{F}$ ) up to  $+230^{\circ}\text{C}$  ( $+446^{\circ}\text{F}$ ), depending on lining material
- Pressure range from 1 mbar (0.01 psi) up to 16 bar (232 psi), depending on size/pressure/temperature

### Testing / Marking

- Pressure- and tightness testing acc. to EN 12266-1, leakage rate A, resp. API 598.
- Marking of valves on body and name plate acc. to EN 19.
- Material- resp. test certificates acc. to EN 10204-3.1/2.2/2.1

### Outline Drawing / Actuator Options

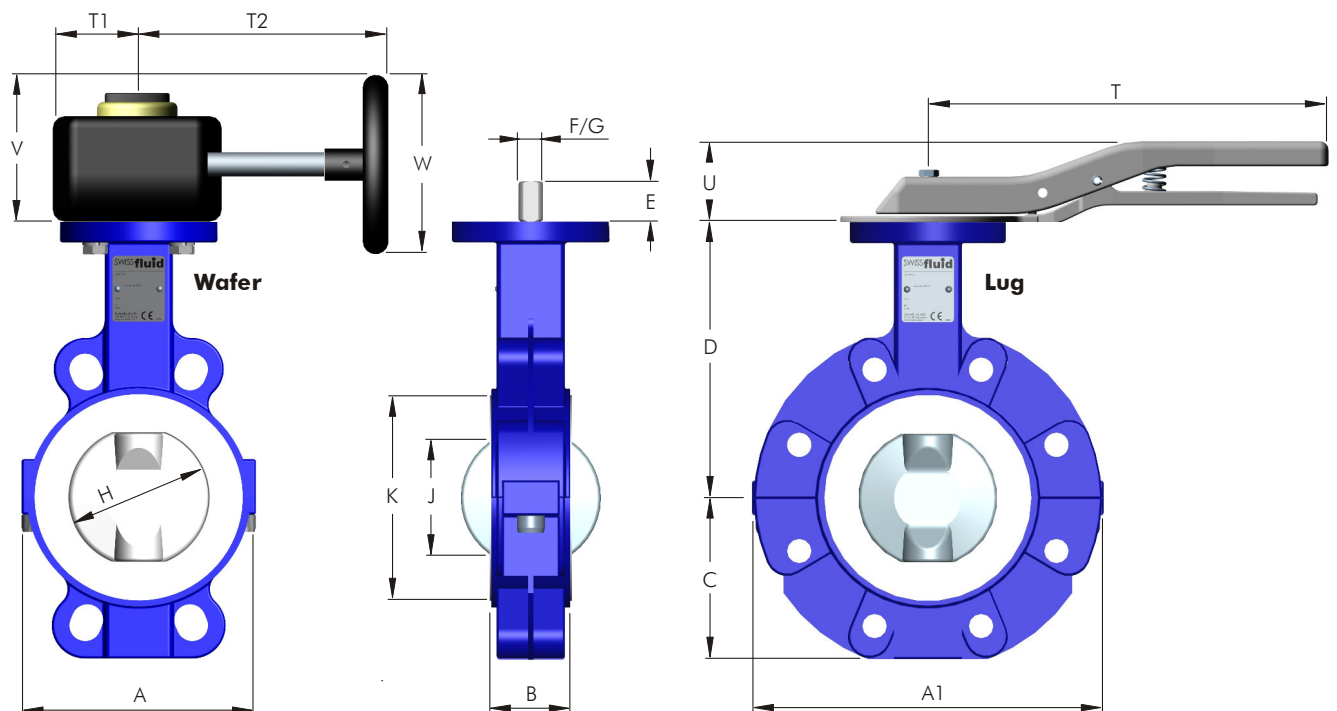

Dimensions in mm

DN Size nom.	A	A1	B	C	D	E	F	G	H	J	K	ISO Top	T	T1	T2	U	V	W
25/1"	-	115	33	46	87	23	14	11	35	10	64	F05	230	58	110	46	90	125
32/1¼"	-	115	33	46	87	23	14	11	35	10	64	F05	230	58	110	46	90	125
40/1½"	-	145	33	64	109	23	14	11	50	38	79	F07	230	58	110	46	90	125
50/2"	118	160	43	69	124	23	14	11	60	42	99	F07	230	58	110	46	90	125
65/2½"	120	180	46	79	144	23	14	11	60	39	104	F07	230	58	110	46	90	125
80/3"	134	202	46	93	159	23	14	11	80	66	119	F07	230	58	110	46	90	125
100/4"	162	232	52	107	184	23	18	14	100	86	144	F07	270	58	110	51	90	125
125/5"	185	269	56	119	199	23	18	14	125	112	169	F07	270	58	110	51	90	125
150/6"	248	289	56	130	209	28	24	17	150	141	199	F07	325	58	200	51	127	200
200/8"	273	349	60	158	239	28	24	17	200	191	249	F10	-	58	200	-	127	200
250/10"	328	400	68	198	264	40	30	22	250	241	309	F10	-	73	280	-	127	200
300/12"	378	470	78	229	264	40	30	22	300	290	359	F10	-	73	280	-	127	200

Face to face B acc. to DIN EN 558-1 range 20

**Construction of Valve**

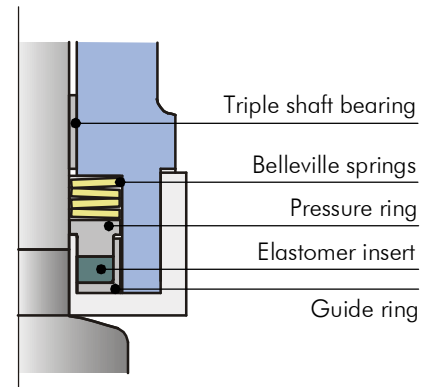
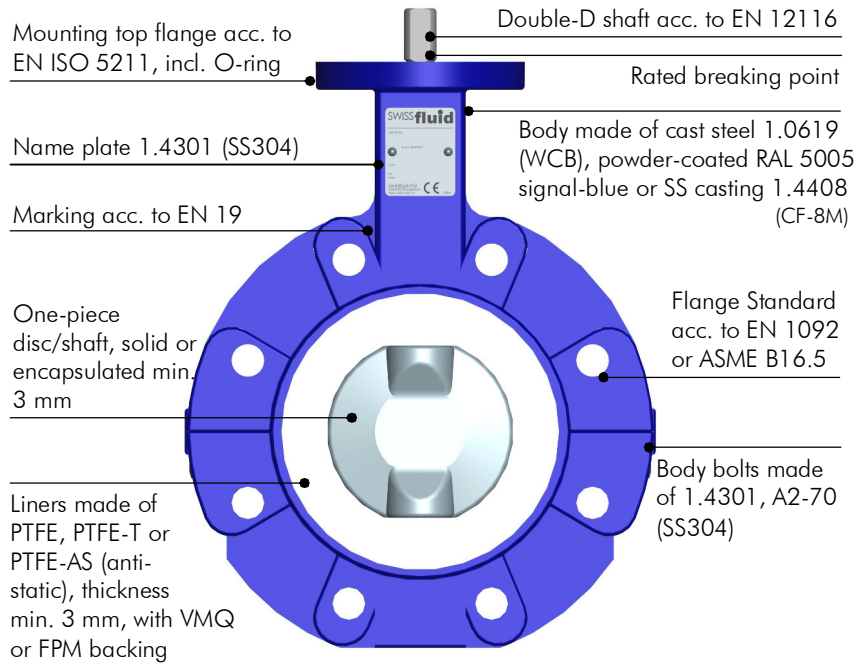

**Dynamic Shaft Seal**

**Mounting Options**

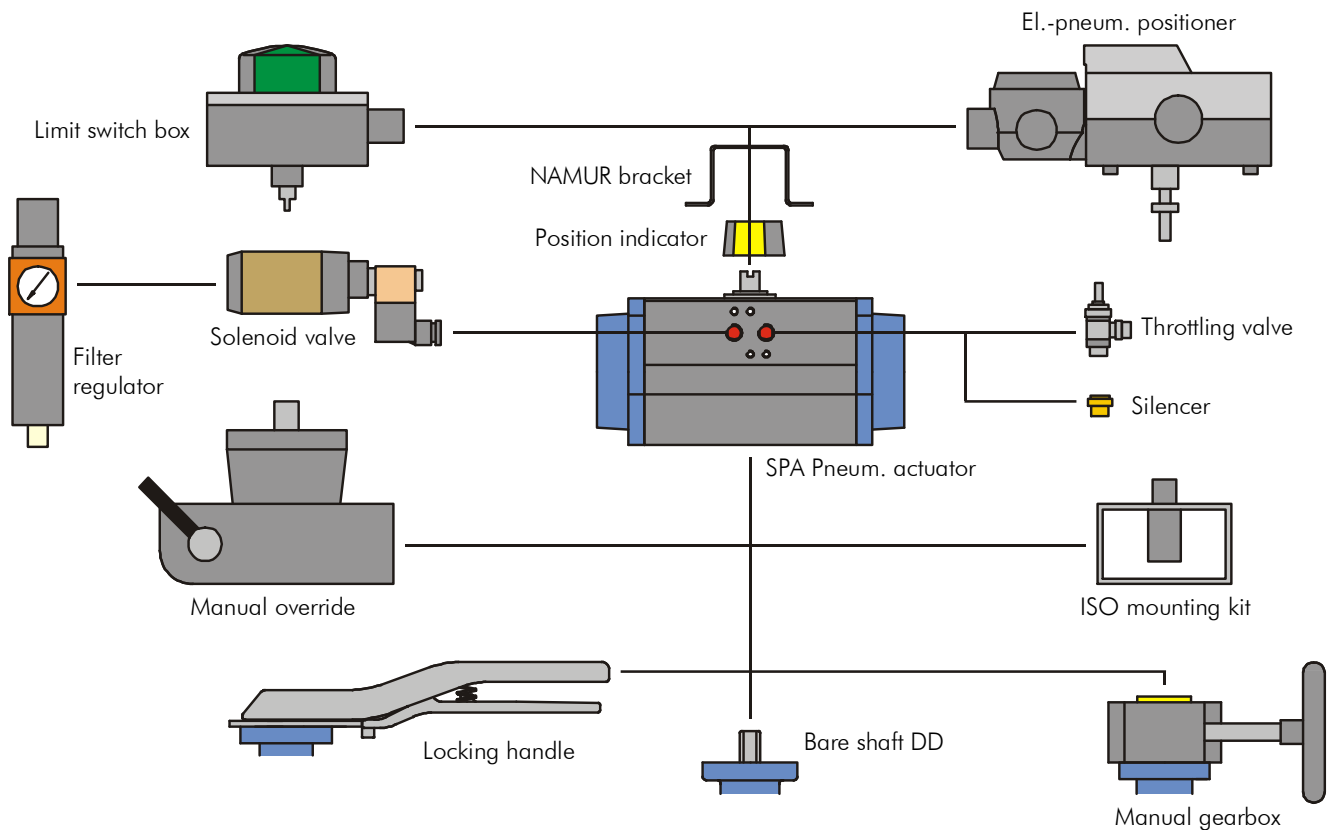

**Pressure-/Temperature Diagram**

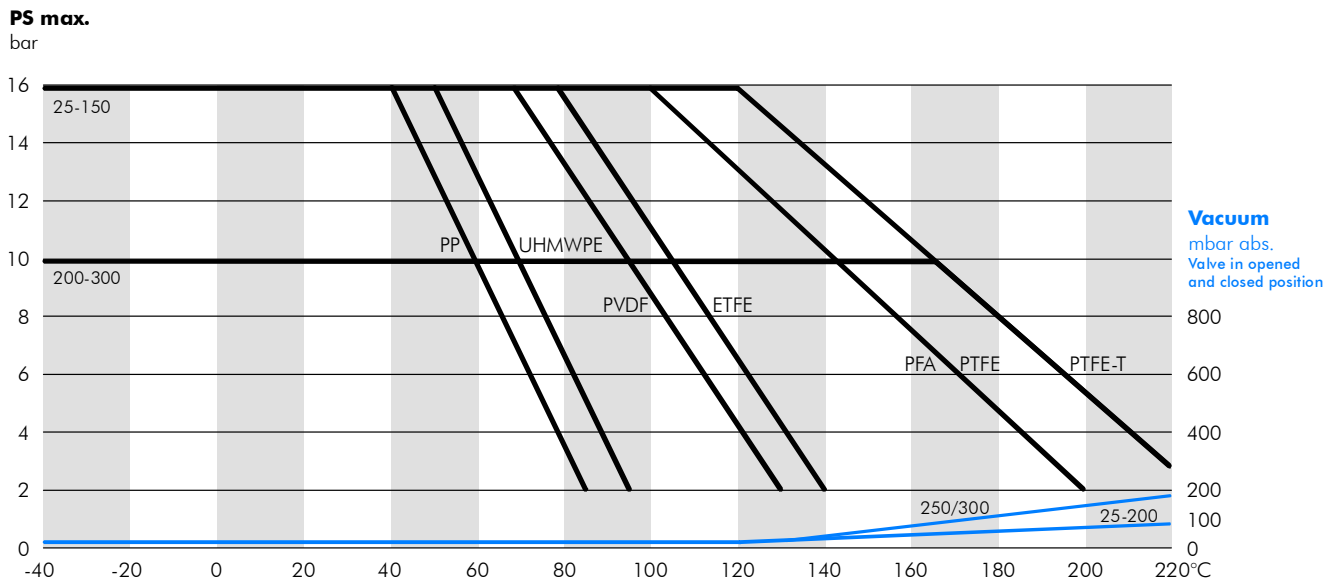

**Torque Values** in Nm (in-lbs = Nm x 8.85)

Torque values for PFA-encapsulated or solid discs and specified body liner

DN Size nom.	25/32	40	50	65	80	100	125	150	200	250	300
<b>A80</b> PTFE	20	25	30	30	40	50	60	110	180	250	350
<b>A81</b> PTFE-T	22	28	33	33	44	55	66	122	198	275	385
<b>A82</b> PTFE-AS	20	25	30	30	40	50	60	110	180	250	350
<b>A89</b> PP	32	40	45	45	60	75	90	165	270	375	525
<b>A90</b> UHMWPE	28	35	40	40	52	65	78	140	230	325	455
max. allowable	145	145	145	145	145	320	320	700	700	1'200	1'200

- For liner resp. disc encapsulation never use for both the same material, otherwise considerable increase of torque values must be expected!
- Stated values to be break-away torques without any consideration of safety factors for actuators.

**Weights** in kg (lbs = kg x 2.2)

Figures stated for execution PTFE/PFA/bare shaft

Size DN	25/32	40	50	65	80	100	125	150	200	250	300
<b>Lug</b> -style body	2.3	3.2	4.7	6.0	6.5	8.5	10.6	13.9	17.9	27.2	35.9
<b>Wafer</b> -style body	-	-	3.3	4.2	4.3	6.3	7.6	10.9	16.2	24.1	31.2
Locking handle	0.9	0.9	0.90	0.9	0.9	1.2	1.2	1.5	-	-	-
Gearbox GG25	2.3	2.3	2.3	2.3	2.3	2.3	2.3	3.5	3.5	6.8	6.8

Weights for pneumatic actuators acc. to separate data sheet

**Flow Rate Values Cv** usg/min.

Estimated values at corresponding opening angle of valve disc

DN Size	25/32	40	50	65	80	100	125	150	200	250	300
20°	3	6	8	8	17	23	44	70	110	203	307
30°	5	13	19	19	38	56	95	151	267	406	606
40°	9	28	41	41	83	110	191	273	539	824	1'154
50°	16	50	70	70	145	188	296	458	922	1'346	1'995
60°	26	74	107	107	220	296	528	748	1'369	1'868	3'091
70°	37	107	153	153	313	447	748	1'108	2'105	2'807	4'599
80°	46	139	197	197	389	563	945	1415	2796	4234	6914
90°	58	158	224	224	455	679	1'177	1'734	3'538	5'232	8'364

**Flow Characteristic**

Opening angle of valve disc

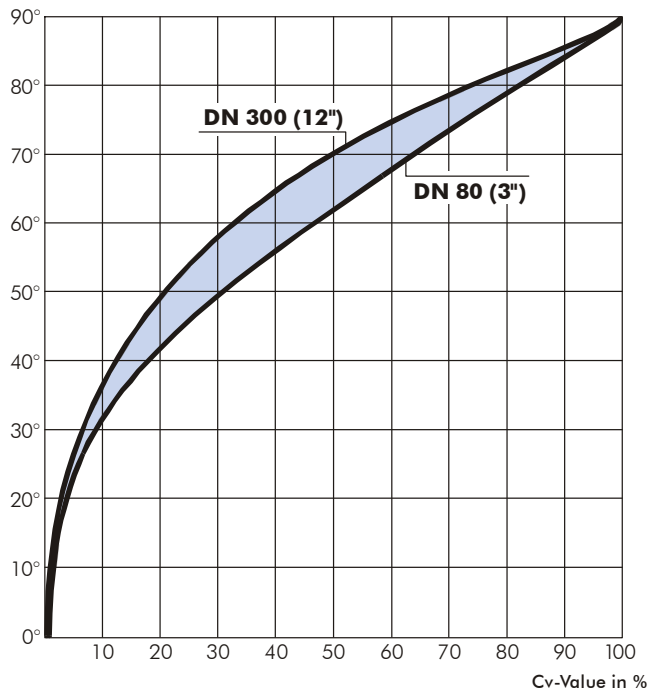

Liquids:

$$K_v = Q \sqrt{\frac{SG}{\Delta p}}$$

Gases:

$$K_v = \frac{Q_N}{514} \sqrt{\frac{SG_N \cdot T}{\Delta p \cdot P_2}}$$

Streamline Flow Contour for Maximum Capacity !

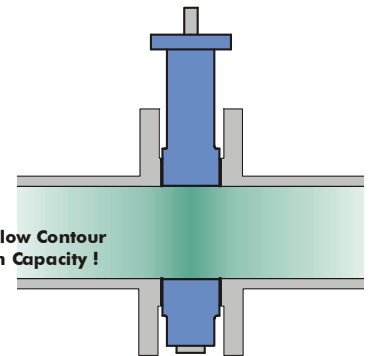

$$^{\circ}K = ^{\circ}C + 273$$

$$K_v = C_v / 1.16$$

<b>Cv (Kv)</b>	Valve Coefficient	usg/min (m <sup>3</sup> /h)
<b>Q</b>	Flow Rate	usg/min (m <sup>3</sup> /h)
<b>Q<sub>N</sub></b>	Flow Rate	usg/min (Nm <sup>3</sup> /h)
<b>SG</b>	Specific Gravity	lbs/usg (kg/dm <sup>3</sup> )
<b>SG<sub>N</sub></b>	Specific Gravity	lbs/usg (kg/Nm <sup>3</sup> )
<b>P<sub>2</sub></b>	Downstream Pressure	psi (bar)
<b>ΔP</b>	Pressure Drop	psi (bar)
<b>T</b>	Temperature	°K (°C)

**Typical Service Applications**

- Chemical CPI
- Petro-Chemical
- Pharmaceutical Industry
- Semi-Conductors
- Pulp and Paper
- Food Processing
- Paint and Pigments
- Fertilizers
- Mining and Steel
- Desalination

# DN350 – DN600 resp. 14" – 24"

## Pressure-/Temperature Diagram

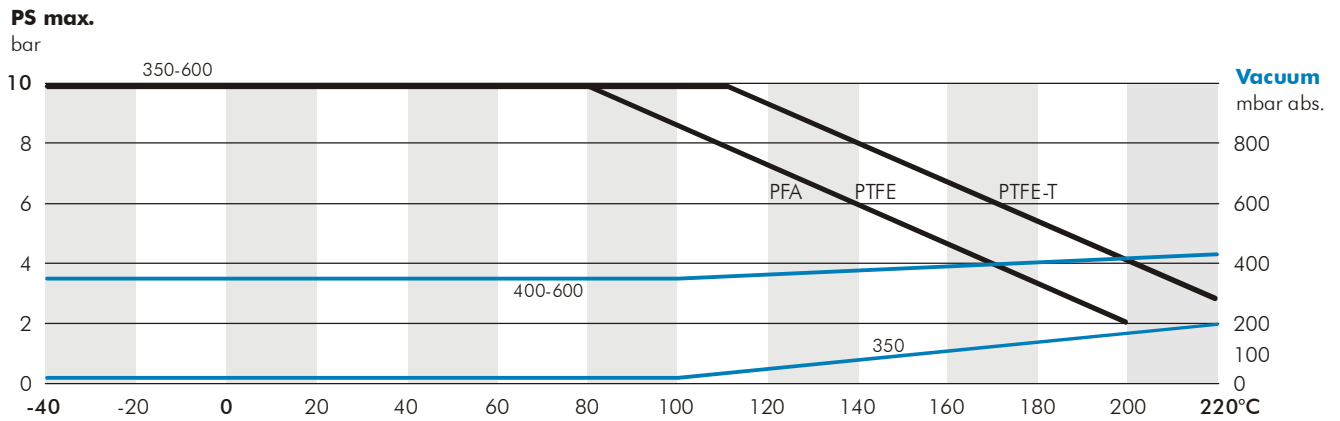

## Dimensions in mm

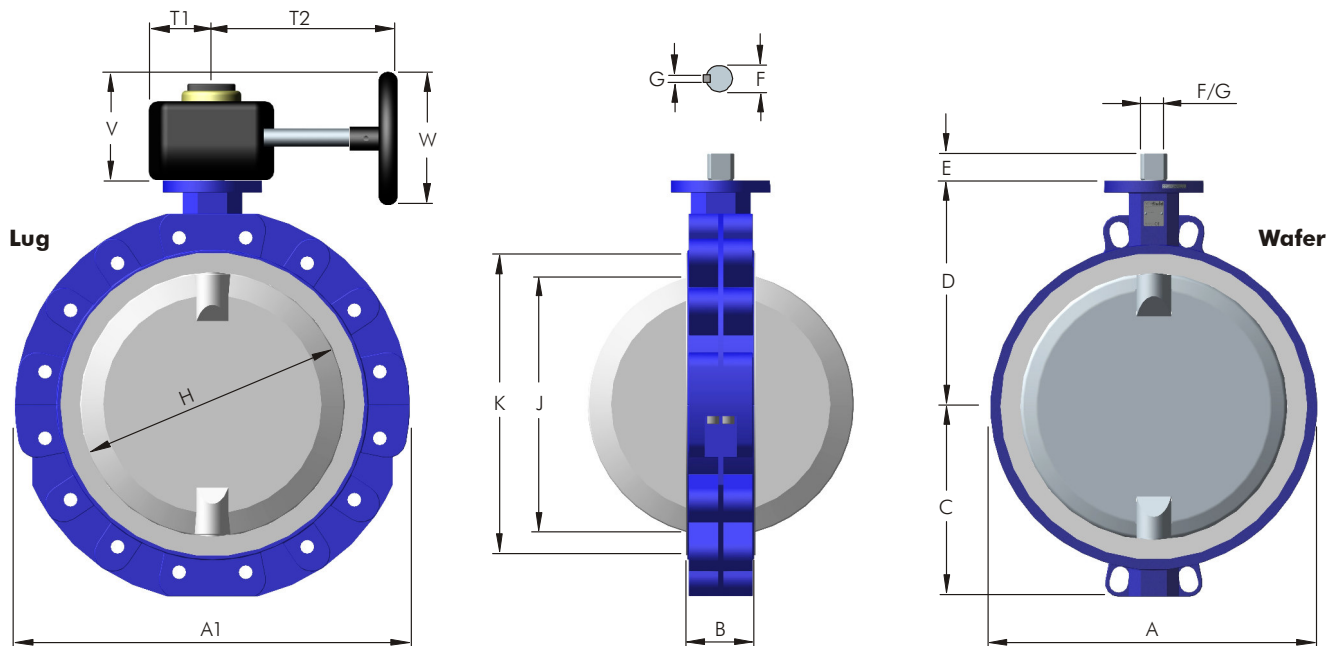

DN Size	A	A1	B	C	D	E	F	G <sup>2)</sup>	H	J	K	ISO	T1	T2	V	W
<b>350/14"</b>	416	530	92	254	309	40	40	27	340	328	409	F12	73	330	190	300
<b>400/16"</b>	462	596	102	289	339	40	40	27	400	387	459	F12	90	350	245	400
<b>450/18"<sup>1)</sup></b>	630	630	114	308	359	50	50	14	450	436	515	F14	90	400	245	400
<b>500/20"</b>	566	698	127	339	390	50	50	14	500	484	569	F14	90	400	245	400
<b>600/24"</b>	668	812	154	399	449	50	50	14	600	578	669	F14	90	400	245	400

Face to face B acc. to DIN EN 558-1 Range 20

B: DN350/14": optional 78 mm , Range 25, ASME B16.10 wide

<sup>1)</sup> Wafer 450/18" made of Lug bodies with drilled-through holes

<sup>2)</sup> G: DN350/400 with DD drive, DN450-600 with 1x Keyway

**Torque Values** in Nm (in-lbs = Nm x 8.85)

Torque values for PFA-encapsulated disc and specified body liner

DN Size	350	400	450	500	600
<b>A80</b> PTFE	450	600	740	900	1'200
<b>A81</b> PTFE-T	495	660	815	990	1'320
<b>A82</b> PTFE-AS	450	600	740	900	1'200
max. allowable	1'800	1'800	2'000	2'000	2'000

- For liner resp. disc encapsulation never use for both the same material, otherwise considerable increase of torque values must be expected!
- Stated values to be break-away torques without any consideration of safety factors for actuators.

**Weights** in kg (lbs = kg x 2.2)

Figures stated for execution PTFE/PFA/bare shaft

DN Size	350	400	450	500	600
<b>Lug</b> -style body	87.0	101.0	137.0	158.0	242.0
<b>Wafer</b> -style body	57.0	69.0	137.0*	96.0	141.0
Gearbox GG25	6.8	6.8	10.0	10.0	10.0

Weights for pneumatic actuators acc. to separate data sheet

\* Wafer 450/18" made of Lug bodies with drilled-through holes

**Flow Rate Values Cv** usg/min

Estimated values at corresponding opening angle of valve disc

DN Size	350	400	450	500	600
<b>20°</b>	406	592	771	1'032	1'473
<b>30°</b>	766	1'143	1'456	1'879	2'494
<b>40°</b>	1'369	1'717	2'587	3'457	4'849
<b>50°</b>	2'088	2'842	4'466	6'206	8'607
<b>60°</b>	3'341	4'907	7'250	9'454	13'166
<b>70°</b>	5'278	7'598	10'672	13'688	19'082
<b>80°</b>	8'329	10'730	14'210	18'050	24'592
<b>90°</b>	10'162	13'166	17'284	20'880	28'420

Same values to be applied on Butterfly Valves SBE Series elastomer-lined

$K_v = C_v / 1.16$       °K = °C + 273

<b>Kv</b> (Cv)	Valve Coefficient	m <sup>3</sup> /h (usg/min)
<b>Q</b>	Flow Rate	m <sup>3</sup> /h (usg/min)
<b>Q<sub>N</sub></b>	Flow Rate	Nm <sup>3</sup> /h (usg/min)
<b>SG</b>	Specific Gravity	kg/dm <sup>3</sup> (lbs/usg)
<b>SG<sub>N</sub></b>	Specific Gravity	kg/Nm <sup>3</sup> (lbs/usg)
<b>P<sub>2</sub></b>	Downstream Pressure	bar (psi)
<b>ΔP</b>	Pressure Drop	bar (psi)
<b>T</b>	Temperature	°C (°K)

**Liquids:**

$$K_v = Q \sqrt{\frac{SG}{\Delta p}}$$

**Gases:**

$$K_v = \frac{Q_N}{514} \sqrt{\frac{SG_N \cdot T}{\Delta p \cdot P_2}}$$

# DN700 – DN1000 resp. 28" – 42"

## Pressure-/Temperature Diagram

PS max.  
bar

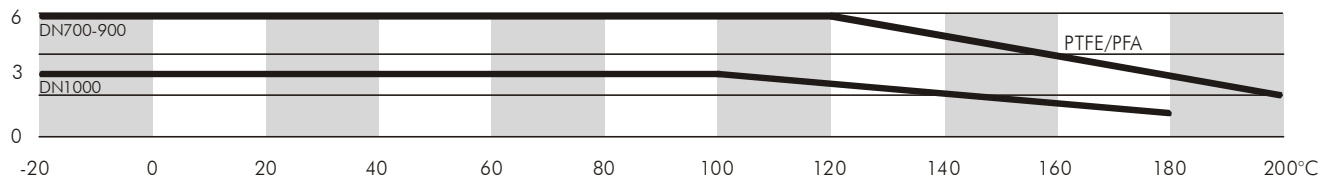

## Dimensions in mm

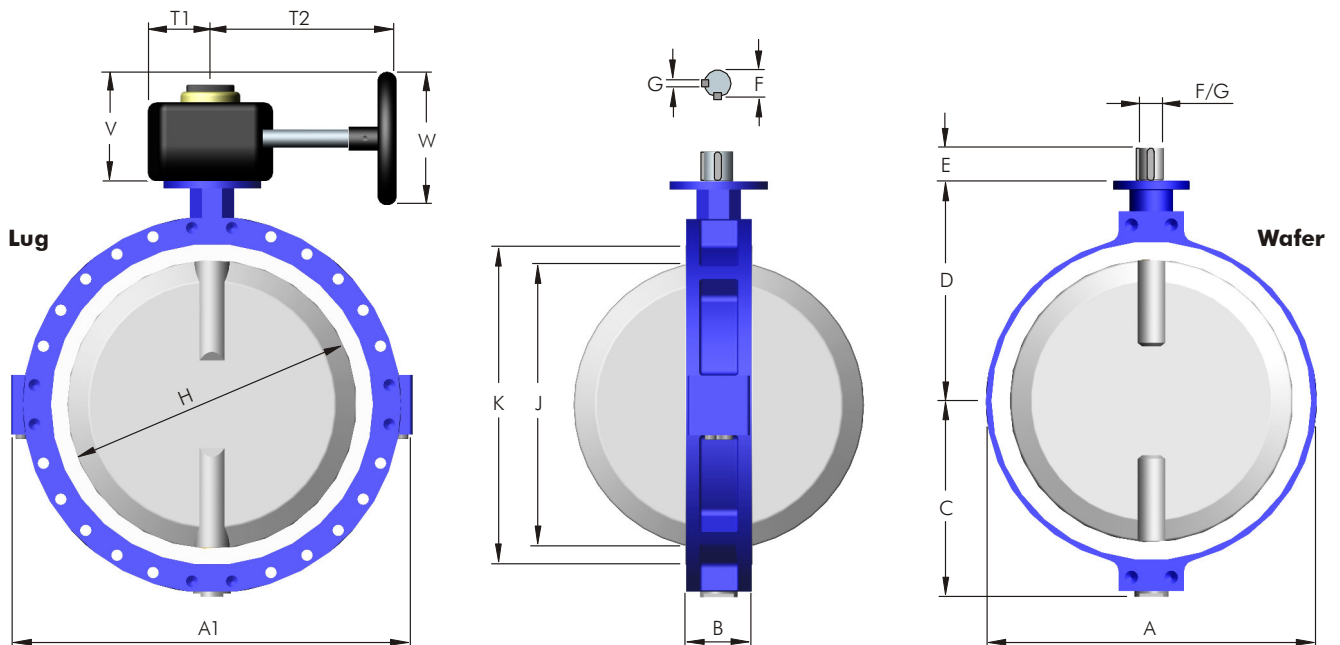

DN Size	A	A1	B	C	D	E	F	G <sup>1)</sup>	H	J	K	ISO	T1	T2	V	W
<b>700/28"</b>	805	1020	165	476	558	50	50	14	680	660	779	F14	143	450	327	500
<b>30"</b>	1110	1110	165	540	608	90	70	20	740	721	839	F16	143	450	327	500
<b>800/32"</b>	1110	1110	165	540	608	90	70	20	780	761	839	F16	143	450	327	500
<b>900/36"</b>	1220	1220	203	586	685	90	90	25	880	856	980	F25	170	450	330	500
<b>1000/42"</b>	1420	1420	216	754	768	90	100	28	1000	976	1100	F25	170	450	330	500

F/F acc. to DIN EN 558-1 Range 20 resp. ASME B1.6.10

Wafer bodies from 30" up to DN1000/42" made of Lug-style bodies with drilled-through flange holes, other versions upon request

<sup>1)</sup> 2x keyway 90° offset

## Torque Values in Nm (in-lbs = Nm x 8.85)

Torque values for PFA-encapsulated disc and specified body liner

DN Size	700/28"	30"	800/32"	900/36"	1000/42"
<b>A80 PTFE</b>	1'760	1'980	2'090	2'640	3'300
max. allowable	2'400	4'000	4'000	5'000	5'000

• Stated values to be break-away torques without any consideration of safety factors for actuators.



**Weights** in kg (lbs = kg x 2.2)

Figures stated for execution PTFE/PFA/bare shaft

DN Size	700/28"	30"	800/32"	900/36"	1000/42"
Lug-style body	410	480	600	800	990
Wafer-style	300	480*	600*	800*	990*
Gearbox GG25	75	75	75	75	75

\* Wafer 30", DN800/32", DN900/36" and DN1000/42" made of Lug-style bodies with drilled-through flange holes

Weights for pneumatic actuators acc. to separate data sheet

**Flow Rate Values Cv** usg/min (Kv = Cv / 1.16)

700/28"	30"	800/32"	900/36"	1000/42"
41'920	46'850	49'390	66'440	73'760

Parts List

Valve compl.

**Standard Version** (Picture showing DN 80 PN16, PTFE liner, PFA-encapsulated disc, bare shaft)

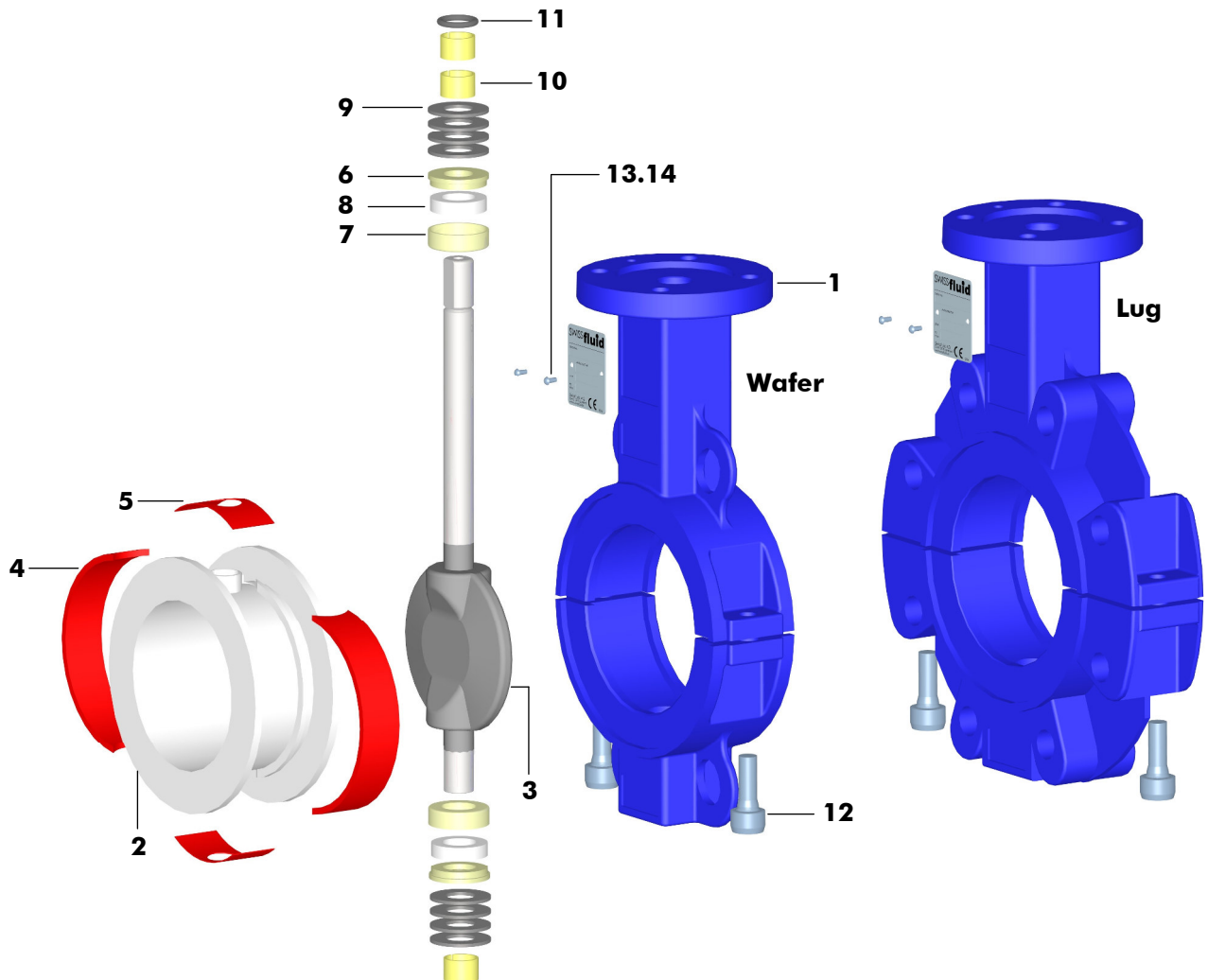

Item	Qty.	Description	Material	No.
1	1	Body two-piece, RAL 5005 (Wafer-style or Lug)	WCB	1.0619
2	1	Liner	PTFE	
3	1	Disc encapsulated	Duplex/PFA	1.4462
4	2	Elastomer	VMQ	
5	2	Elastomer Pad	VMQ	
6	2	Pressure Ring	C.Steel	1.0737
7	2	Guide Ring	C.Steel	1.0737
8	2	Elastomer Insert	VMQ	
9	8	Belleville Spring	Spring Steel	1.8159
10	3	Bearing DU	C.Steel/PTFE	
11	1	O-Ring top	FPM	
12	2	Socked Head Cap Screw	A2-70	1.4310
13	1	Name Plate 42 x 14 CE	A2	1.4301
14	2	Hammer Screw 2.49 x 4.76	A2	1.4310