

Angle Seat Control Valve 7020 with integrated positioner

DN 8 up to DN 80 PN 40

Pneumatically operated control valves for neutral through to highly aggressive media.

- Integrated positioner
- Compact design
- All parts contacting the fluid made from stainless steel
- Temperatures up to 200°C
- Working pressure up to 40 bar



Control valve with integrated microprocessor-positioner for the control of neutral through to aggressive media in process engineering, chemical industry and for plant equipment.

- Space saving design and low weight
- No steady-state air consumption
- Operation independent of mounting position and supply pressure variations
- Not sensitive to vibration
- Instrument grade air not essential
- Software configurable flow characteristics
- Protection Class IP65



**Type 7020
with digital positioner
Type 8049**

Optionen

- e.g.:
- Optical position indicator
 - External I/P-converter Type 8045
 - Ex-electropneumatic positioner
( II 2 G EEx ib IIC T6)

Technical Information

Body material	Stainless steel 1.4408
Nominal sizes	DN 8 up to DN 80
Connections	
Pipe thread acc. ISO 228-1	DN 8 up to DN 80
NPT thread	DN 8 up to DN 80
Welding ends	DN15 up to DN 65
Nominal pressure	PN40
Fluid temperature*	-30°C up to +200°C
Ambient temperature**	-15°C up to +80°C

*: Please consider further temperature versions and limits in technical bulletin 32

** : Please consider the limitation of use of the positioner

Angle Seat Control Valve 7020

Standart design with integrated positioner

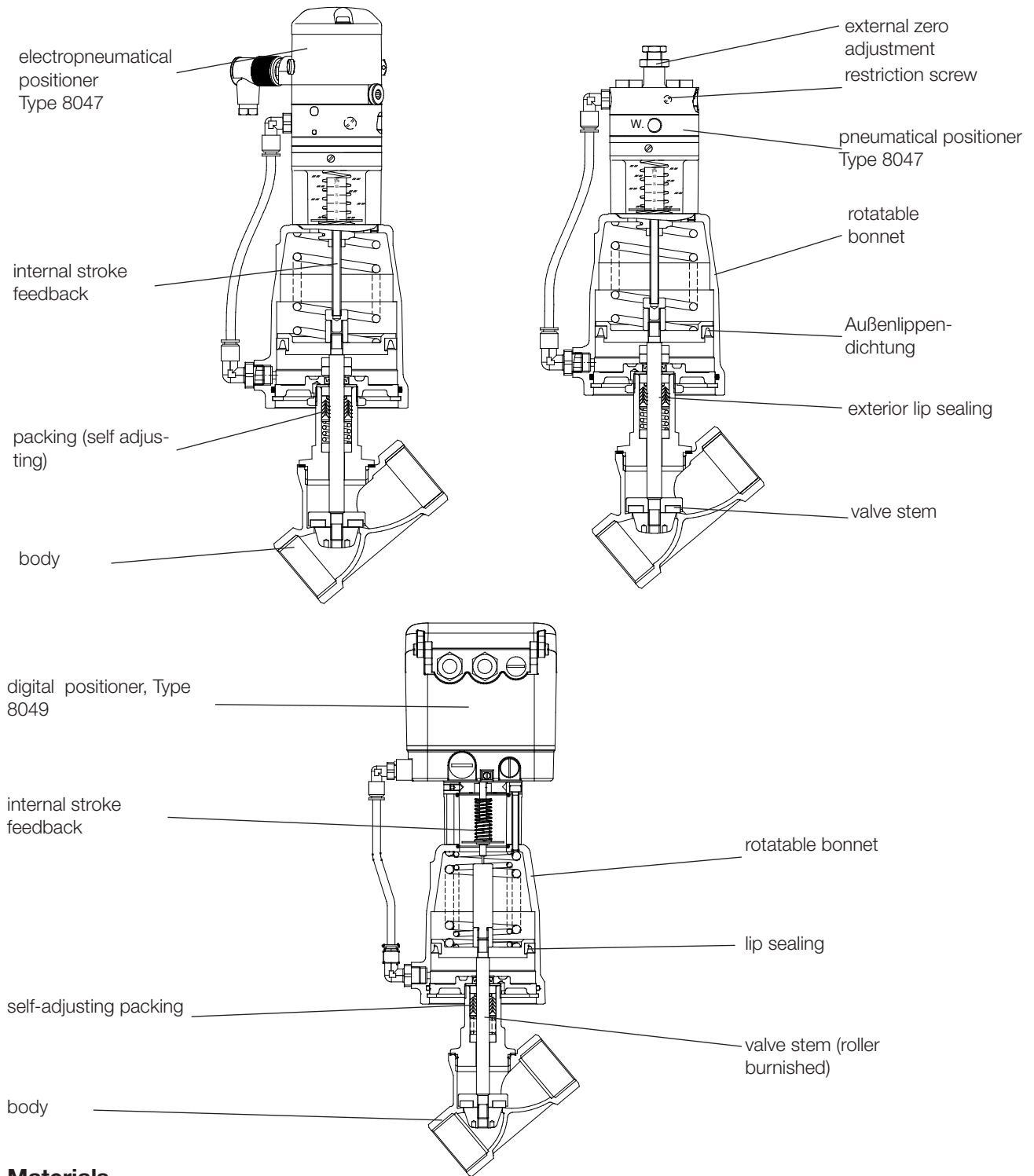

Materials

Body	Stainless steel 1.4408
Seating seal	PTFE
Bonnet	Brass chrome plated (actuator Ø 50 mm, 80 mm) Aluminium corrosion protected (actuator Ø 125 mm)
Diaphragm actuator	Stainless steel 1.4301/1.4305
Actuator springs	Stainless steel 1.4310 (actuator Ø 50 mm, 80 mm, diaphr.act.) Spring steel wire C, zinc coated (actuator Ø 125 mm)
Packing	PTFE (carbon filled), spring 1.4310
Valve stem	Stainless steel 1.4571, roller burnished
Position indicator	PA Trogamid (clear)

Angle Seat Control Valve 7020



Standard design with integrated positioner

Positioner

For technical information of our positioners please refer to the corresponding data sheets.

Admissible Differential Pressures

digital positioner

DN	Differential pressure	Supply pressure range	Piston Ø	Springs
	bar	bar	mm	Number
8	17	4 - 6	80	2 *
15	17	4 - 6	80	2
20	17	4 - 6	80	2
25	17	4 - 6	80	1
25	17	3 - 6	250	4
32	10	4 - 6	80	1
32	17	3 - 6	125	2
32	17	3 - 6	250	4
40	6	4 - 6	80	1
40	17	4 - 6	125	3
40	17	3 - 6	250	6

* special springs

p/p- and i/p-positioner

DN	Differential pressure	Supply pressure range	Piston Ø	Springs
	bar	bar	mm	Number
8	17	4 - 6	80	2 *
15	17	4 - 6	80	2
20	17	4 - 6	80	2
25	12	4 - 6	80	1
25	11	2,8 - 6	250	4
32	7	4 - 6	80	1
32	13	3 - 6	125	2
32	17	2,8 - 6	250	6
40	4	4 - 6	80	1
40	11	4 - 6	125	3
40	15	3,4 - 6	250	8

* special springs

diaphragm actuator, direct pressure range

DN	Differential pressure (bar)		Max. pressure (no) (bar)		Supply air (bar)		Diaphragm area (mm)
	spring range 0,2 - 1 bar	spring range 0,4 - 2 bar	spring range 0,2 - 1 bar	spring range 0,4 - 2 bar	spring range 0,2 - 1 bar	spring range 0,4 - 2 bar	
15	17	17	17	17	1,2	2,4	250
20	16	17	17	17	1,2	2,4	250
25	9	17	12	15	1,2	2,4	250
32	5	15	6	13	1,2	2,4	250
40	3	10	2	5	1,2	2,4	250
50	2	6	1	2	1,2	2,4	250

Kvs-Values

DN	linear						equal percentage					
	8	15	20	25	32	40	8	15	20	25	32	40
100%	0,6	3,8	8,8	14	20	27	0,6	3	6	10	16	25
40%	0,24	1,5	3,5	5,8	8	11	-	1,2	2,4	4	6	10
25%	0,15	0,93	2,2	3,6	-	-	-	0,8	1,5	2,6	-	-
15%	-	-	-	-	-	-	-	0,46	-	-	-	-
10%	-	0,4	-	-	-	-	-	-	-	-	-	-
7,5%	-	-	-	-	-	-	-	0,23	-	-	-	-

Angle Seat Control Valve 7020

Reinforced design with integrated positioner

DN50 up to DN80, PN40

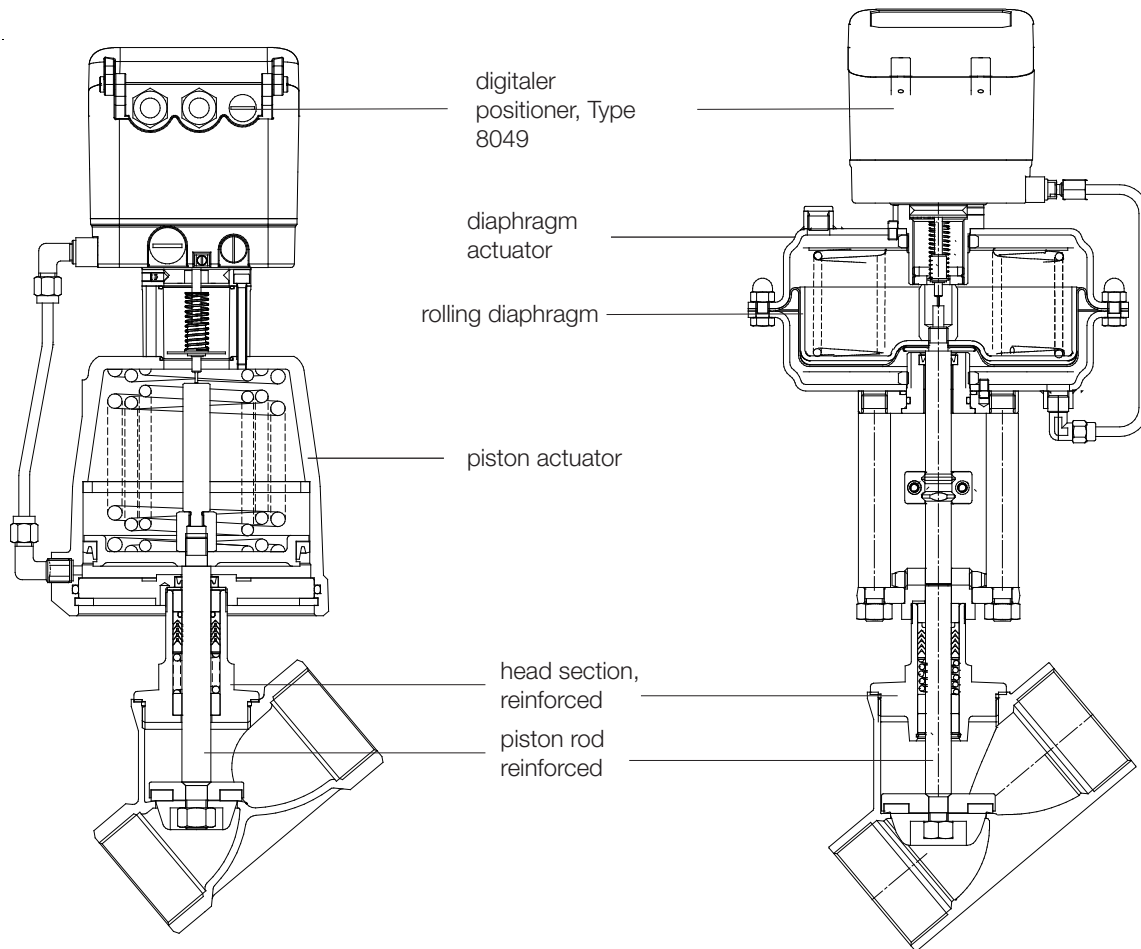

Admissible Differential Pressures

digital positioner

DN	Differential pressure (bar)		Supply pressure range bar	Piston Ø mm	Springs number
	PTFE	PEEK			
50	3	-	4 - 6	80	1
50	11	3	4 - 6	125	3
50	12	5	3 - 6	250	6 *
50	17	10	4 - 6	250	8
50	17	17	4 - 6	250	12 *
65	5	-	4 - 6	125	3
65	13	8	4 - 6	250	12
80	3	-	4 - 6	125	3
80	9	5	4 - 6	250	12

p/p- and i/p-positioner

DN	Differential pressure (bar)		Supply pressure range bar	Piston Ø mm	Springs number
	PTFE				
50	2		4 - 6	80	1
50	6		4 - 6	125	3
50	13		4 - 6	250	10*
50	16,9		4 - 6	250	12
65	9,3		4 - 6	250	12
80	6,3		4 - 6	250	12

* special spring configuration

Kvs-Values

DN	linear			equal percentage		
	50	65	80	50	65	80
100%	43	52	69	34	44	59
63%	26	32	-	23	29	-

Angle Seat Control Valve 7020



with integrated positioner

Ordering Number System

7	0	2	0	/					V											S		
---	---	---	---	---	--	--	--	--	---	--	--	--	--	--	--	--	--	--	--	---	--	--

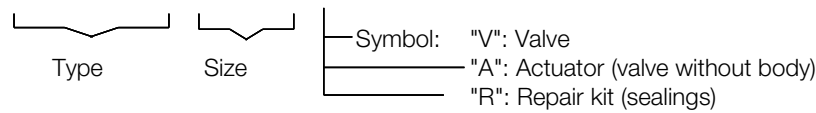

1 - 6 : Please quote all 6 sections.
7 - 14: Quote only if required.

1. Body type	2. Connection	3. Body materials	4. Seat material	5. Positioner	6. Actuator	7. Springs
1 angle body control valve Type 7020	0 pipe thread ISO 228-1 5 NPT thread 6 without thread D welding ends acc. DIN11850 H welding ends acc. ISO	2 stainless steel 1.4408	0 PTFE	6 p/p positioner, Type 8047 7 i/p positioner, Type 8047 8 i/p positioner with plug connection M12x1, Type 8047 9 i/p positioner ex-proof (II 2 G Eex ib IIC T6), plug connection M12x1, Type 8047 C digital positioner, Type 8049 4 wire R digital positioner Type 8049 2 wire T digital positioner Type 8049 AS-i version W digital positioner Type 8049 2 wire, ex-version	1 piston 80 mm 2 piston 125 mm C diaphragm D 250mm	- without significance 1 spring to open (only with digital positioner) P spring set 0,2-1bar (D 250mm) T 6 springs (D 250mm) W 8 springs (D 250mm) Y 12 springs (D 250mm)
8. Characteristic	9. Packing	10. Kvs-value	11. Accessories	12. Special versions	13. Seal	14. Position indicator
- linear 1 equal percentage	- standard packing underneath 2	- full Kvs-value 1 red. to 40% 2 red. to 25% 3 red. to 15% 4 red. to 7,5% 5 red. to 22,5% 6 red.to 10%	- without pilot-valve DN2 230V AC 6 7 pilot-valve DN2 24V DC	S To state if some stations are quoted!	- standard	0 with position indicator (dig. positioner standard)

Ordering Example: 7020/020V1620C1
 Angle Seat Control Valve, nominal size DN 20, without thread, stainless steel, PTFE seat material, N.C., digital positioner Typ 8049, 4-wire, with position indicator, piston Ø 80 mm, linear characteristic, Kvs-value = 8,8

reinforced design (from DN50):

Ordering Example: 7020/050V1620C1-----S-----K
 Angle Seat Control Valve, nominal size DN 50, without thread, stainless steel, PTFE seat material, N.C., digital positioner Typ 8049, 4-wire, with position indicator, piston Ø 80 mm, linear characteristic, Kvs-value = 43, reinforced design
„K“ reinforced design

Angle Seat Control Valve 7020

Piston actuator with integrated positioner

Dimensions and Weights

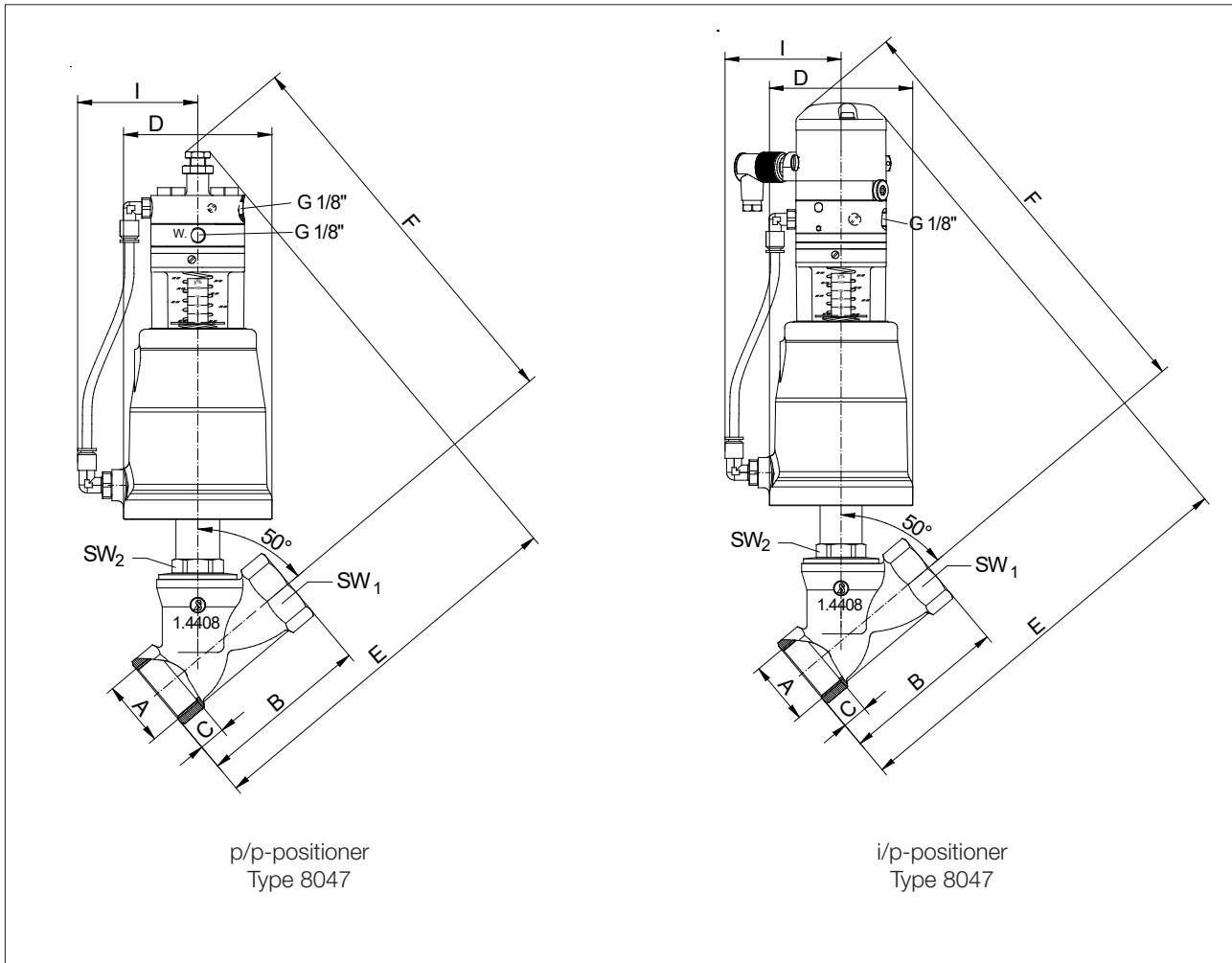

DN	Actuator	A G/NPT	B	C	D	E		F		I	SW1	SW2	Weight (kg)	
						Positioner		Positioner					p/p	i/p
						p/p	i/p	p/p	i/p					
8	80	1/4"	60	12	96	220	250	230	260	80	20	30	3,7	4,0
15	80	1/2"	65	15	96	220	250	230	260	80	25	30	3,7	4,0
20	80	3/4"	75	16,3	96	225	255	235	265	80	31	30	3,8	4,1
25	80	1"	90	19,1	96	235	265	240	270	80	39	30	4,0	4,3
32	80	1 1/4"	110	21,4	96	250	280	255	285	80	48	30	4,3	4,6
32	125	1 1/4"	110	21,4	146	265	295	275	305	105	48	30	6,9	7,2
40	80	1 1/2"	120	21,4	96	255	285	260	290	80	55	30	4,6	4,9
40	125	1 1/2"	120	21,4	146	270	300	280	310	105	55	30	7,2	7,5

reinforced design:

50	80	2"	150	21	96	275	305	270	300	80	68	32	5,3	5,5
50	125	2"	150	25,7	146	285	315	285	315	105	68	32	7,8	8,1

Dimensions in mm

Angle Seat Control Valve 7020

Piston actuator with integrated positioner

Dimensions and Weight

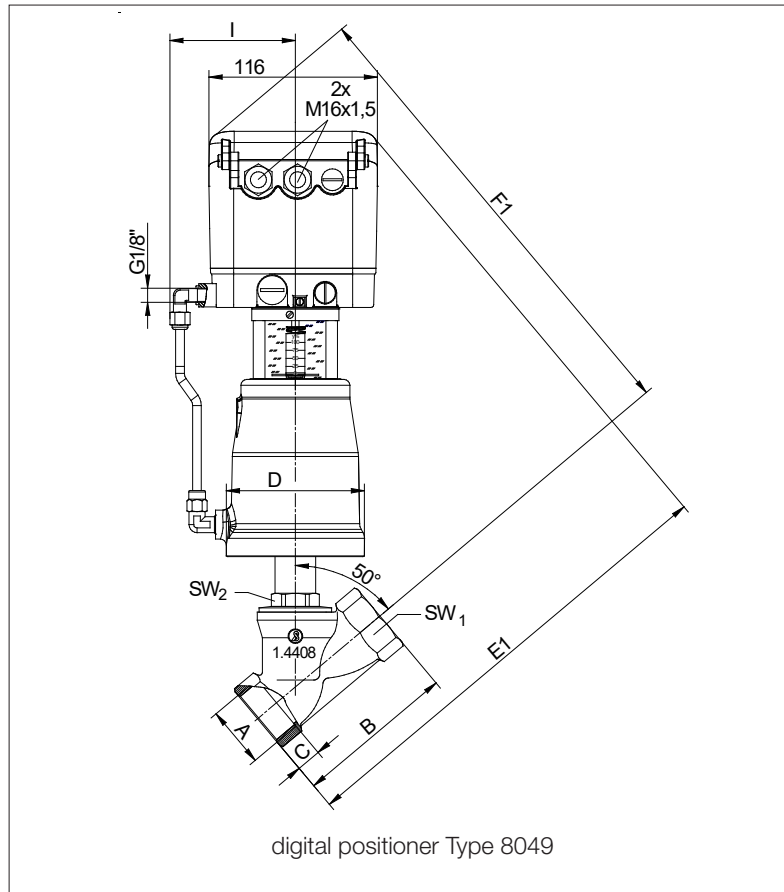

DN	Actuator	A G/NPT	B	C	D	E	F	I	SW1	SW2	Weight (kg)
8	80	3/8"	60	12	96	287	304	80	20	30	4,2
15	80	1/2"	65	12	96	309	301	80	25	30	4,4
20	80	3/4"	75	13	96	314	306	80	31	30	4,5
25	80	1"	90	15	96	324	311	80	39	30	4,7
32	80	1 1/4"	110	17	96	339	326	80	48	30	5,0
32	125	1 1/4"	110	17	146	369	356	105	48	30	7,6
40	80	1 1/2"	120	19	96	344	331	80	55	30	5,3
40	125	1 1/2"	120	19	146	374	361	105	55	30	7,9

reinforced design:

50	80	2"	150	25,7	96	350	350	80	68	32	5,9
50	125	2"	150	26	146	365	365	105	68	32	8,5
65	125	2 1/2"	180	30	146	385	380	105	85	36	8,9
80	125	3"	214	34	146	435	380	105	100	41	11,4

Dimensions in mm

Angle Seat Control Valve 7020

Diaphragm actuator with integrated positioner

Dimensions and Weights

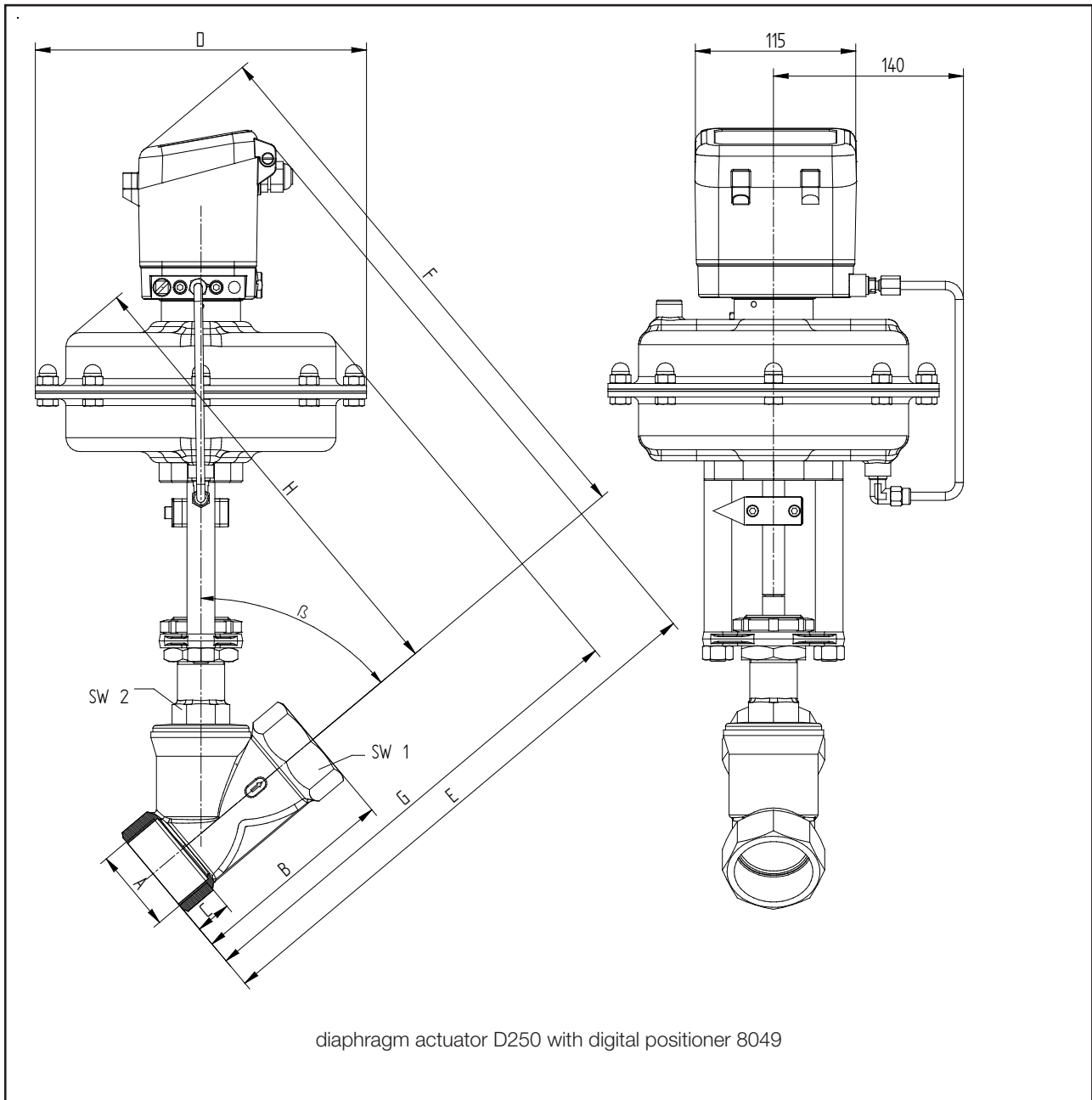

DN	A	B	C	D	E	F	G	H	SW1	SW2	Angle β	Weight kg
15	G 1/2"	65	15	238	340	350	285	280	25	30	50°	15,6
20	G 3/4"	75	16,3	238	350	360	295	290	31	30	50°	15,7
25	G 1"	90	19,1	238	360	370	305	300	39	30	50°	15,9
32	G 1 1/4"	110	21,4	238	370	385	315	310	48	30	50°	16
40	G 1/2"	120	21,4	238	380	395	325	320	55	30	50°	16,2
50	G 2"	150	25,7	238	410	410	350	335	68	36	50°	16,5
65	G 2 1/2"	180	30,2	238	425	420	370	350	85	36	50°	16,9
80	G 3"	214	33,5	238	475	410	410	355	100	41	45°	19,4

Dimensions in mm