

1/2" – 6" RP (red. port)

SCP Cylindrical Plug Valves are ideally suited for Shut-off, Flow Control and Throttling of corrosive, abrasive or even toxic process media in either liquid or gaseous state.

Modular Design

Valves are available with handlever for manual quarter turn operation as per standard or with bare shaft for easy installation of actuator units.

The sturdy design bodies are made of cast steel 1.0619 (WCB), epoxy coating RAL 5005 signal-blue or stainless steel casting 1.4408 (CF-8M), with resistant linings such as PFA or PFA-AS (conductive).



Main Features

- Heavy-duty, robust construction, maintenance-free
- Bubble-tight shut-off throughout the full pressure and temperature range
- Cavity-free design, max. permeation protection
- Zero stem leakage provided by an innovative stem sealing mechanism
- Consistent low operating torque through cylindrical plug design and resilient liner/cylinder contact
- Maximum flow rates at lowest pressure drops
- Easy replacement of components on site
- Flange connections acc. to ANSI 150lbs (DIN optional) for installation into existing piping systems

 **Conformity according to European Pressure Equipment Directive 97/23/EC (PED)**

Operating Options



Standard Valve

Body 1.0619 (WCB)/PFA, bare shaft

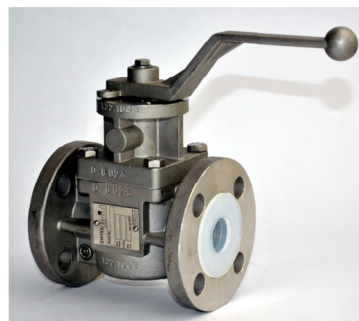

Stainless Steel

Body CF-8M/PFA, with handlever

Operating Conditions

- Temperature range from -40°F up to +400°F, depending on lining material
- Pressure range from 0.01 psia up to 232 psi, depending on size/pressure/temperature

Testing / Marking

- Pressure- and tightness testing acc. to EN 12266-1, leakage rate A, resp. API 598.
- Marking of valves on body and name plate acc. to EN 19.
- Material- resp. test certificates acc. to EN 10204-3.1/2.2/2.1

Outline Drawing / Actuator Options

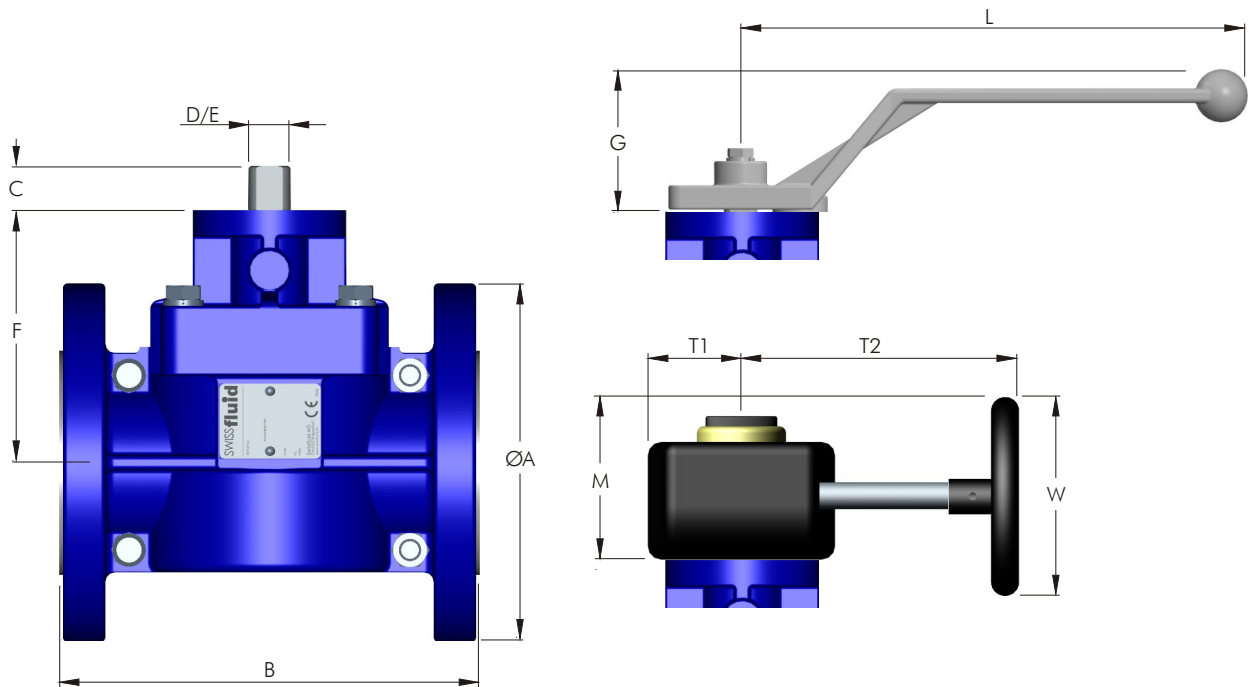

Dimensions inch

Weights lbs

Size nom.	ØA	B	C	D Dia.	E DD	F	G	L	M	T1	T2	W Dia.	ISO Top	Valve only	Lever only	Gear only
1/2"	3.74	5.12	0.75	0.55	0.43	3.39	2.28	8.31	3.54	2.28	4.33	4.92	F05	7.04	0.79	5.06
3/4"	4.13	5.91	0.75	0.55	0.43	3.50	2.28	8.31	3.54	2.28	4.33	4.92	F05	8.36	0.79	5.06
1"	4.25	5.00	0.75	0.55	0.43	3.62	2.28	8.31	3.54	2.28	4.33	4.92	F05	7.92	0.79	5.06
1 1/2"	5.00	6.50	0.75	0.71	0.55	4.02	2.28	9.88	3.54	2.28	4.33	4.92	F07	11.88	0.90	5.06
2"	6.00	7.00	0.75	0.71	0.55	4.21	2.28	9.88	3.54	2.28	4.33	4.92	F07	18.04	0.90	5.06
3" RP	7.50	8.00	0.75	0.71	0.55	4.21	2.28	9.88	3.54	2.28	4.33	4.92	F07	30.36	0.90	5.06
4" RP	9.00	9.00	0.94	0.94	0.67	5.39	2.44	12.40	5.00	2.28	7.87	7.87	F07	50.38	1.98	7.70
6" RP	11.00	10.50	0.94	0.94	0.67	5.79	-	-	5.00	2.28	7.87	7.87	F10	77.00	1.98	7.70

Face to face B acc. to ASME B16.10

Construction of Valve

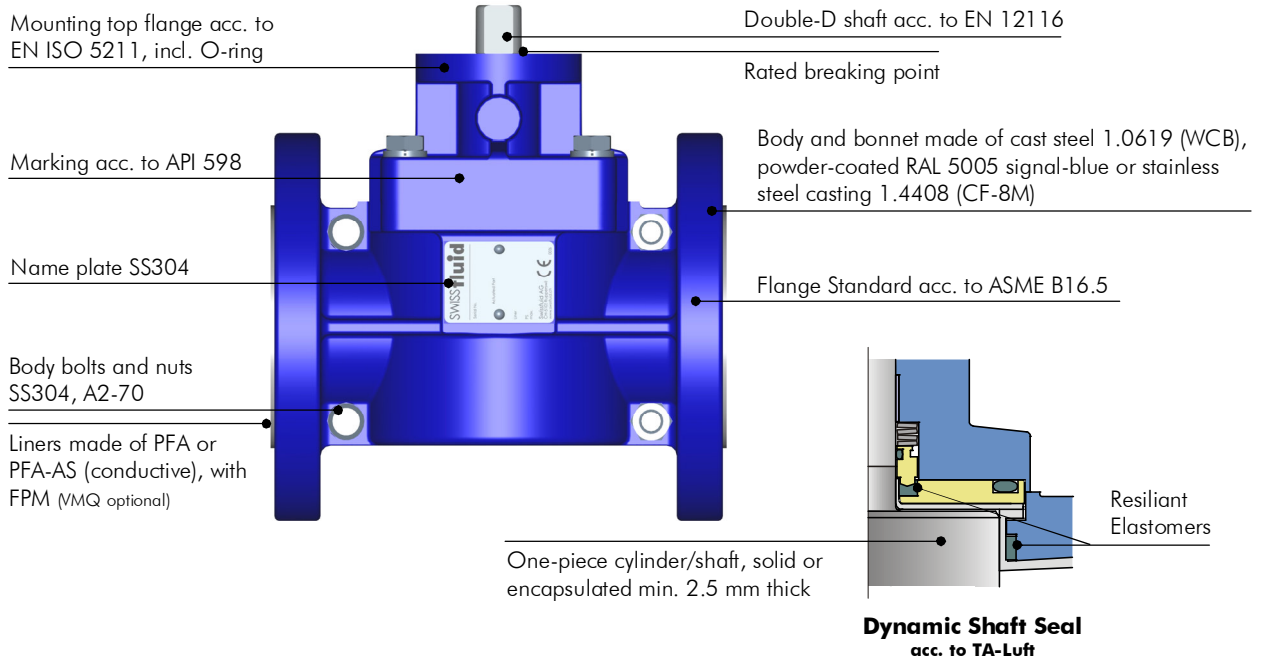

Mounting Options

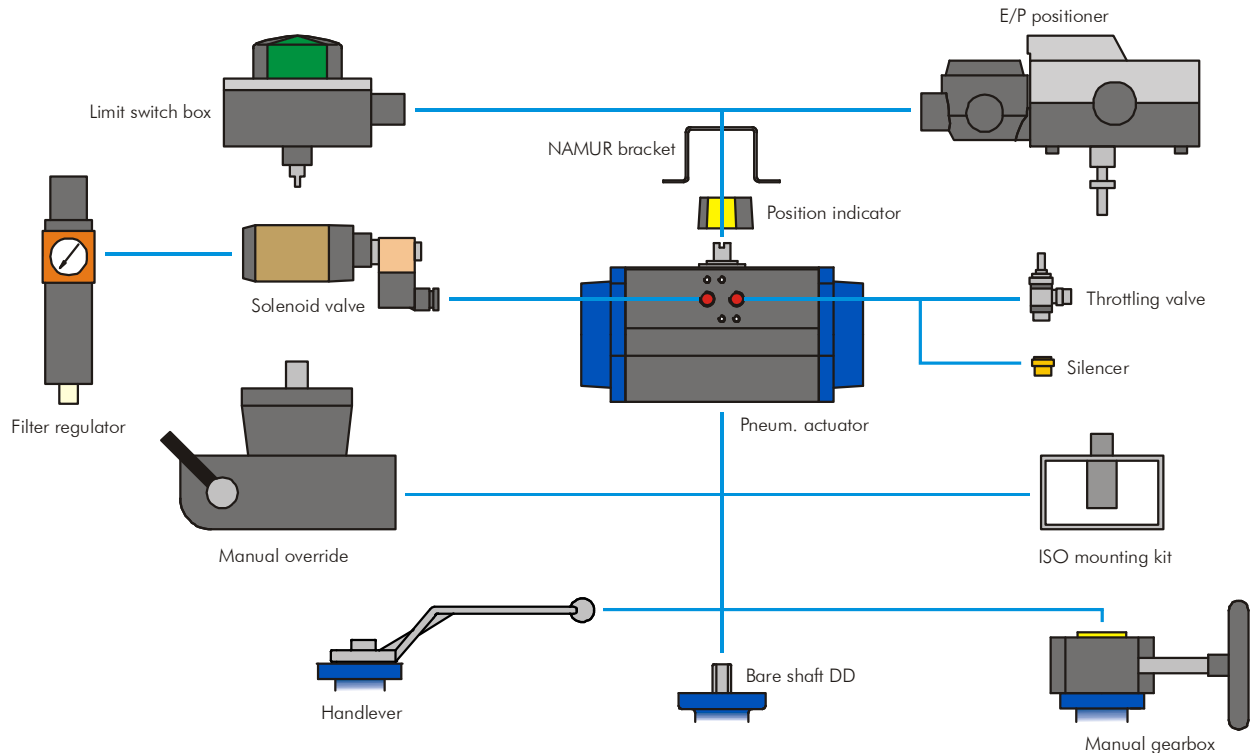

Pressure-/Temperature Diagram

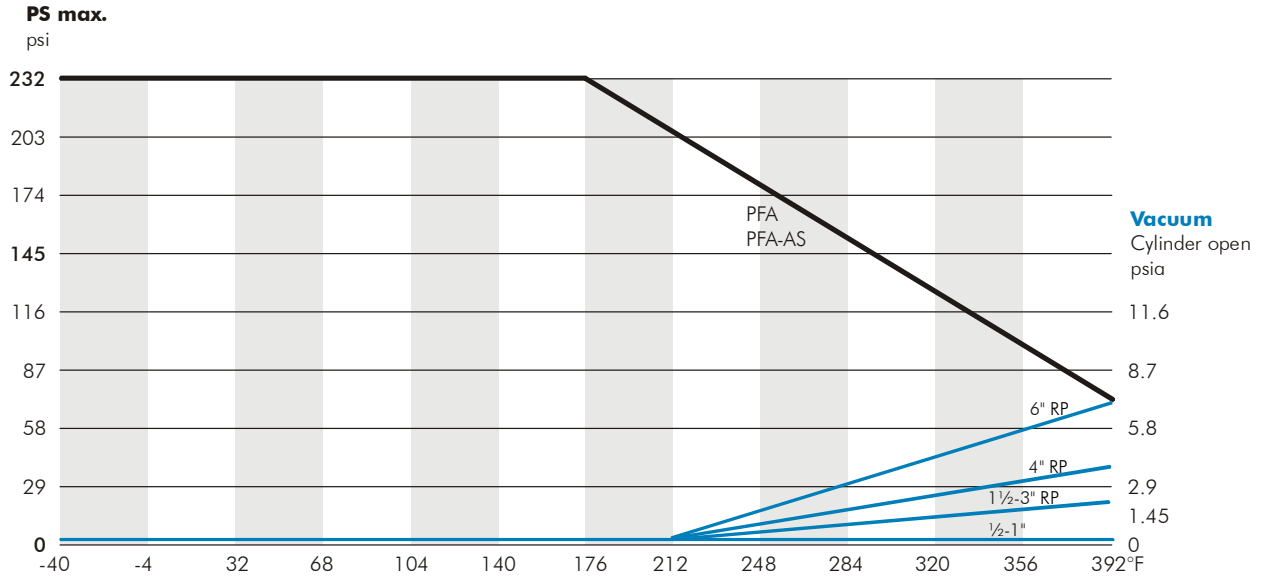

Torque Values in-lbs

Torque values for PFA-encapsulated cylinder and PFA-liner

Size <small>nom.</small>	1/2"	3/4"	1"	1 1/2"	2"/3" RP	4" RP	6" RP
Torque <small>nom.</small>	142	195	248	372	487	974	1,859
max. allowable	1,283	1,283	1,283	2,832	2,832	6,195	6,195

- Stated values to be break-away torques without any consideration of safety factors for actuators.

Flow Rate Values Cv usg/min.

Size <small>nom.</small>	1/2"	3/4"	1"	1 1/2"	2"/3" RP	4" RP	6" RP
Full Port Valve	18	36	70	216	321	930	1,425

Options

V-port Cylinder

for control applications, with various contours

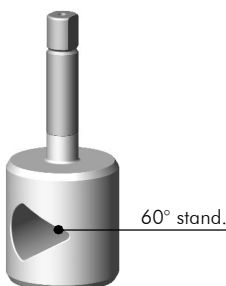

Vented Cylinder

with drilled vent hole for upstream pressure relief

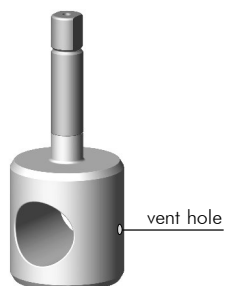

Typical Service Applications

- Chemical CPI
- Petro-Chemical
- Bio-Technical
- Pharmaceutical Industry
- Semi-Conductors
- Pulp and Paper
- Food Processing
- Paint and Pigments
- Fertilizers
- Textile Industry
- Mining and Steel

Parts List
Manual Valve compl.

Standard Version (Picture showing Valve 2"-150lbs, PFA liner, PFA-encapsulated cylinder, bare shaft)

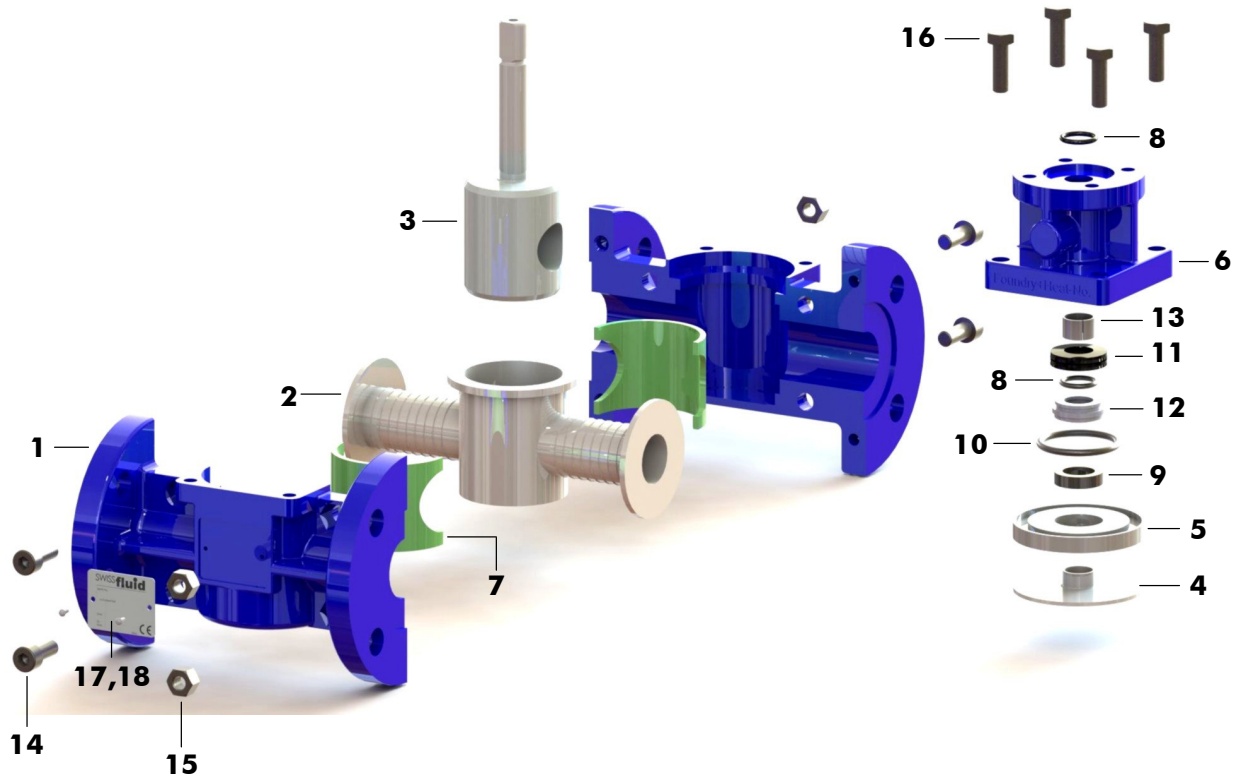

Item	Qty.	Description	Material	No.
1	1	Body two-piece, RAL 5005	WCB	1.0619
2	1	Liner	PFA	
3	1	Cylinder encapsulated	Duplex/PFA	1.4462
4	1	Diaphragm	PTFE	
5	1	Pressure Plate	Duplex	1.4462
6	1	Bonnet, RAL 5005	WCB	1.0619
7	2	Elastomer	FPM	
8	2	O-Ring top	FPM	
9	1	Shaft Seal Ring	FPM	
10	1	O-Ring	FPM	
11	4	Belleville Spring	Spring Steel	1.8159
12	1	Pressure Sleeve	SS316L	1.4404
13	1	Bearing DU	C.Steel/PTFE	
14	4	Socket Head Cap Screw	A2-70	1.4310
15	4	Hex. Nut	A2-70	1.4310
16	4	Hex. Head Screw	A2-70	1.4310
17	1	Name Plate 42 x 14 CE	A2	1.4301
18	2	Hammer Screw 2.49 x 4.76	A2	1.4310