

## DN15 – DN200 RP (red. port) resp. 1/2" – 8" RP (red. port)

Ideally suited for positive shut-off, flow control and throttling of corrosive, abrasive or even toxic process media in either liquid or gaseous state.

### Modular Design

Ball Valves SBV Series are available as DIN- or ANSI-valves, with handlever for manual quarter turn operation as per standard or with bare shaft for easy installation of actuator units.

The sturdy design bodies are made of cast steel 1.0619 (WCB A216), RAL 5005 signal-blue epoxy-coated or compl. of SS316 casting 1.4408 (CF-8M), with resistant linings such as PFA or PFA-AS (conductive).



**CE** Conformity according to European Pressure Equipment Directive 97/23/EC (PED)

### Main Features

- Heavy-duty, robust construction, maintenance-free
- Body halves friction-locked (metal-to-metal)
- Bubble-tight shut-off throughout the full pressure and temperature range
- One-piece ball/shaft, PFA-encapsulated
- Zero stem leakage provided by an innovative stem sealing mechanism
- Consistent low operating torque
- Maximum flow rates at lowest pressure drops
- Integrated ISO top flange for standard actuators
- Flanges acc. to DIN PN16/40 resp. ANSI 150lbs for installation into existing piping systems

### Actuator Options



#### Automated

Body 1.0619 (WCB A216)/PFA-lined, pneumatic quarter turn actuator, DA or FC



#### Stainless Steel

Body 1.4408 (CF-8M)/PFA-lined, bare shaft

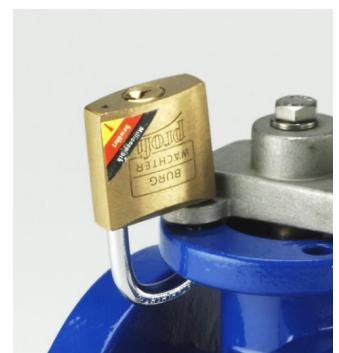

#### Padlock

Handlever on ISO top flange, with safety lock

### Operating Conditions

- Temperature range from -40°C (-40°F) up to +200°C (+392°F), depending on lining material
- Pressure range from 1mbar (0.01 psi) up to 16 bar (232 psi), depending on size/pressure/temperature

### Testing / Marking

- Pressure- and tightness testing acc. to EN 12266-1, leakage rate A, resp. API 598.
- Marking of valves on body and name plate acc. to EN 19.
- Material- resp. test certificates acc. to EN 10204-3.1/2.2/2.1

### Manual Valve

Standard version with handlever

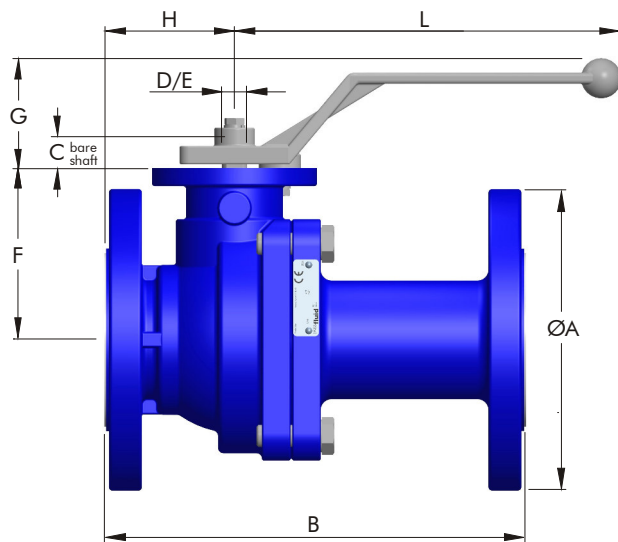

**Dimensions** in mm (lbs = kg x 2.2)

DN Size nom.	ØA DIN	ØA ANSI	B DIN	B ANSI	C shaft end	D dia.	E DD	F	G	H	L	ISO	kg DIN	kg ANSI	kg Handle
15/1/2"	95	95	130	130	19	14	11	64	58	50	161	F05	3.6	3.6	0.32
20/3/4"	105	105	150	150	19	14	11	66	58	50	161	F05	4.5	4.5	0.32
25/1"	115	108	160	127	19	14	11	70	58	50	161	F05	5.3	4.9	0.32
32/1 1/4"	140	140	180	180	19	14	11	75	58	60	161	F05	6.1	6.1	0.32
40/1 1/2"	150	127	200	165	19	14	11	87	58	64	211	F07	9.7	8.6	0.36
50/2"	165	152	230	178	19	14	11	94	58	71	211	F07	12.2	11.3	0.36
65/2 1/2"	185	178	290	190	23	18	14	106	58	77	251	F07	16.8	15.0	0.41
80/3"	200	190	310	203	23	18	14	115	62	81	251	F07	20.3	18.6	0.41
100/4"	220	229	350	229	23	24	17	130	62	92	315	F10	31.0	30.9	0.90
125 red.	250	-	400*	-	23	24	17	130	62	117	315	F10	52.0	-	0.90
5" red.	-	254	-	254	23	24	17	130	62	117	315	F10	-	40.0	0.90
6" red.	-	279	-	267	23	24	17	130	62	112	315	F10	-	38.6	0.90
150/6"	282	282	480*	267	30	30	22	189	-	131	-	F12	92.0	63.6	-
200 red.	340	-	600*	-	30	30	22	189	-	200	-	F12	120.0	-	-
8" red.	-	340	-	292	30	30	22	189	-	200	-	F12	-	83.0	-

Face to face B acc. to DIN EN 558-1 range 1 resp. ASME B16.10, \*DN125/150/200 red. with DIN lengths = ANSI valves with spool piece(s)  
 DN125 red./5" red. and 6" red. with eff. throughput dia. 100 mm, DN200/8" red. with eff. throughput dia. 150 mm

### Manual Valve

Versions with manual gearbox or spring return handlever

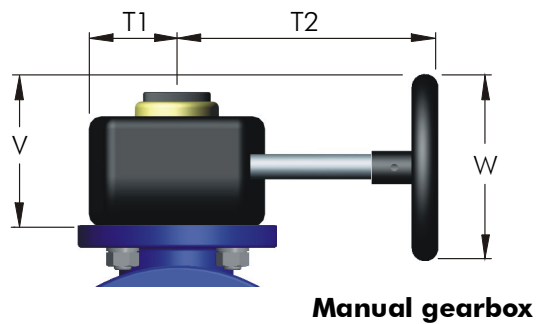
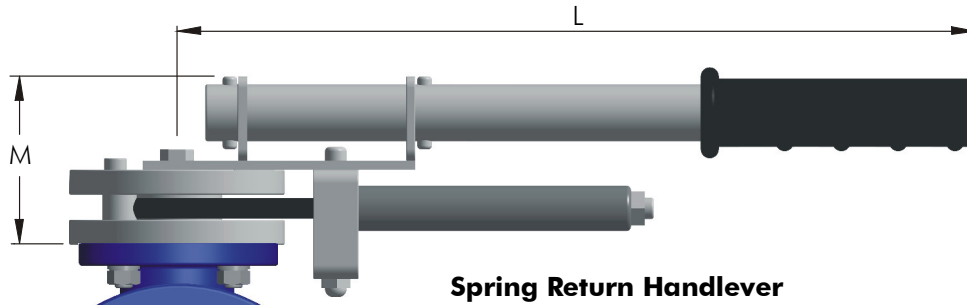

Note: Gearbox and spring return handlever to be mounted onto valve across to pipeline

**Dimensions** in mm (lbs = kg x 2.2)

DN Size nom.	L	M	T1	T2	V	W	kg	
							SR Lever	Gearbox
15/1/2"	347	74	58	110	90	125	1.6	2.3
20/3/4"	347	74	58	110	90	125	1.6	2.3
25/1"	347	74	58	110	90	125	1.6	2.3
32/1 1/4"	416	74	58	110	90	125	2.0	2.3
40/1 1/2"	416	74	58	110	90	125	2.0	2.3
50/2"	416	74	58	110	90	125	2.0	2.3
65/2 1/2"	-	-	58	110	90	125	-	2.3
80/3"	-	-	58	110	90	125	-	2.3
100/4"	-	-	58	200	127	200	-	3.5
125 red./5" red.	-	-	58	200	127	200	-	3.5
6" red.	-	-	58	200	127	200	-	3.5
150/6"	-	-	73	280	190	300	-	6.8
200 red./8" red.	-	-	73	280	190	300	-	6.8

### Construction of Valve

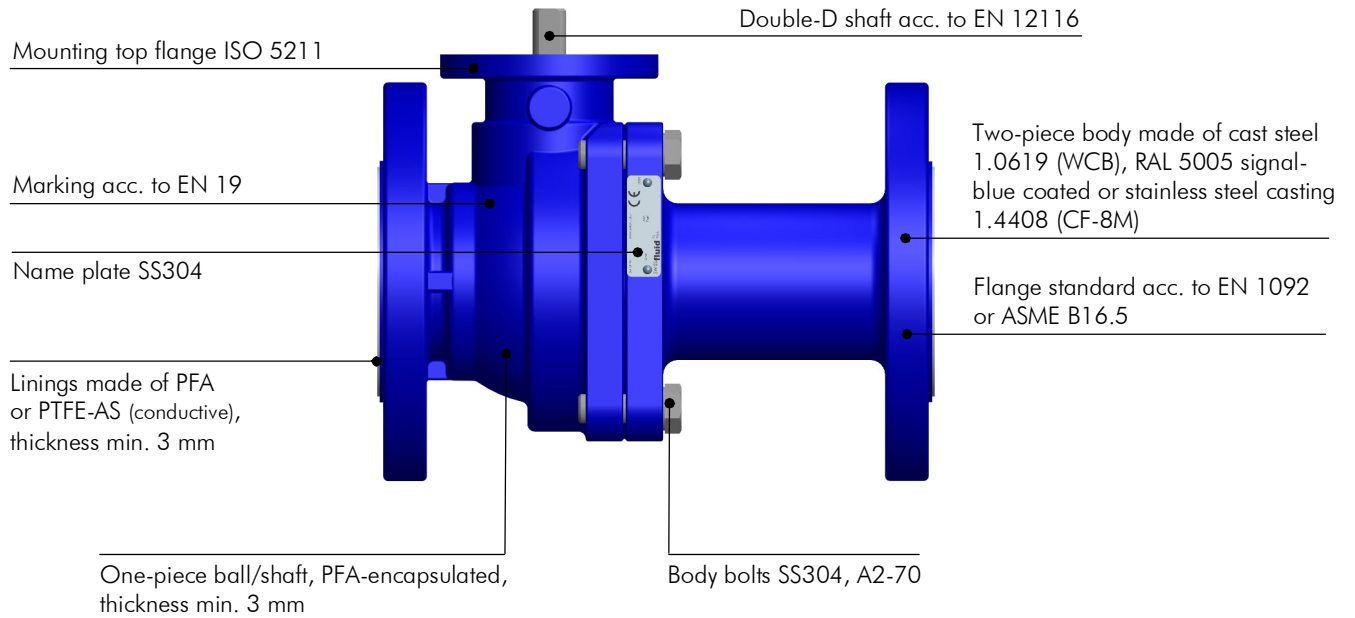

### Mounting Options

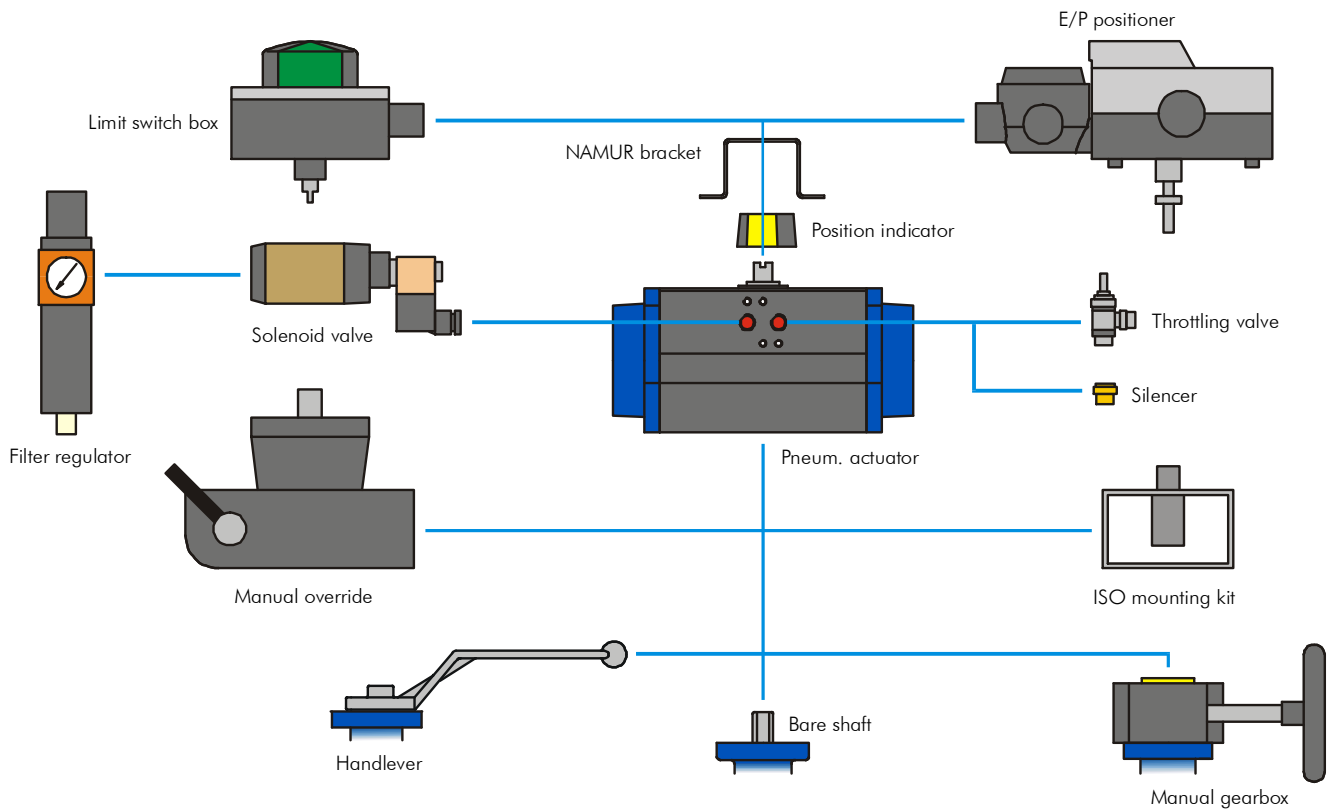

**Pressure-/Temperature Diagram**

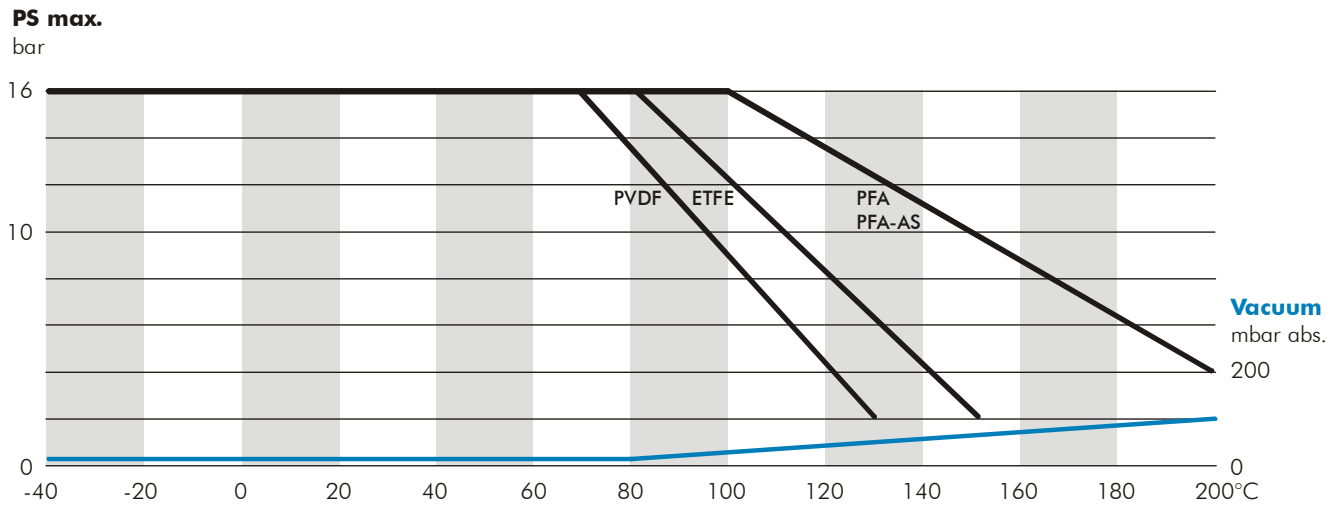

**Torque Values** in Nm (in-lbs = Nm x 8.85)

Max. torque values for PFA-encapsulated balls and PFA-lined bodies

DN Size nom.	15 1/2"	20 3/4"	25 1"	32 1 1/4"	40 1 1/2"	50 2"	65 2 1/2"	80 3"	100/125 red. 4"/5" red. 6" red.	150/200 red. 6"/8" red.
Torque nom.	8	8	12	18	23	30	50	65	95	240
max. allow.	145	145	145	145	206	206	320	320	700	1'200

- Stated values to be break-away torques without any consideration of safety factors (min. 1.3) for pneum. actuators.

**Flow Rate Values Cv** usg/min. (Kv = Cv/1.16)

DN Size nom.	15 1/2"	20 3/4"	25 1"	32 1 1/4"	40 1 1/2"	50 2"	65 2 1/2"	80 3"	100/125 red. 4"/5" red. 6" red.	150/200 red. 6"/8" red.
Flow Rate	18	36	68	139	205	312	610	915	1'405	3'165

**Options**

**Cs-Ball**

to prevent media residues inside ball cavity, for full drainage



**V-Port-Ball**

suitable for control applications, with various contours



**Vented Ball**

with drilled vent hole, suited for upstream pressure relief



**Typical Service Applications**

- Chemical CPI
- Petro-Chemical
- Bio-Technical
- Pharmaceutical Industry
- Pulp and Paper
- Food Processing
- Paint and Pigments
- Fertilizers
- Textile Industry
- Mining and Steel
- Water Treatment
- ...

Parts List

Manual Valve compl.

**Standard Version** (Picture showing Valve DN50 PN16 WCB A216, PFA-lined, with Handlever)

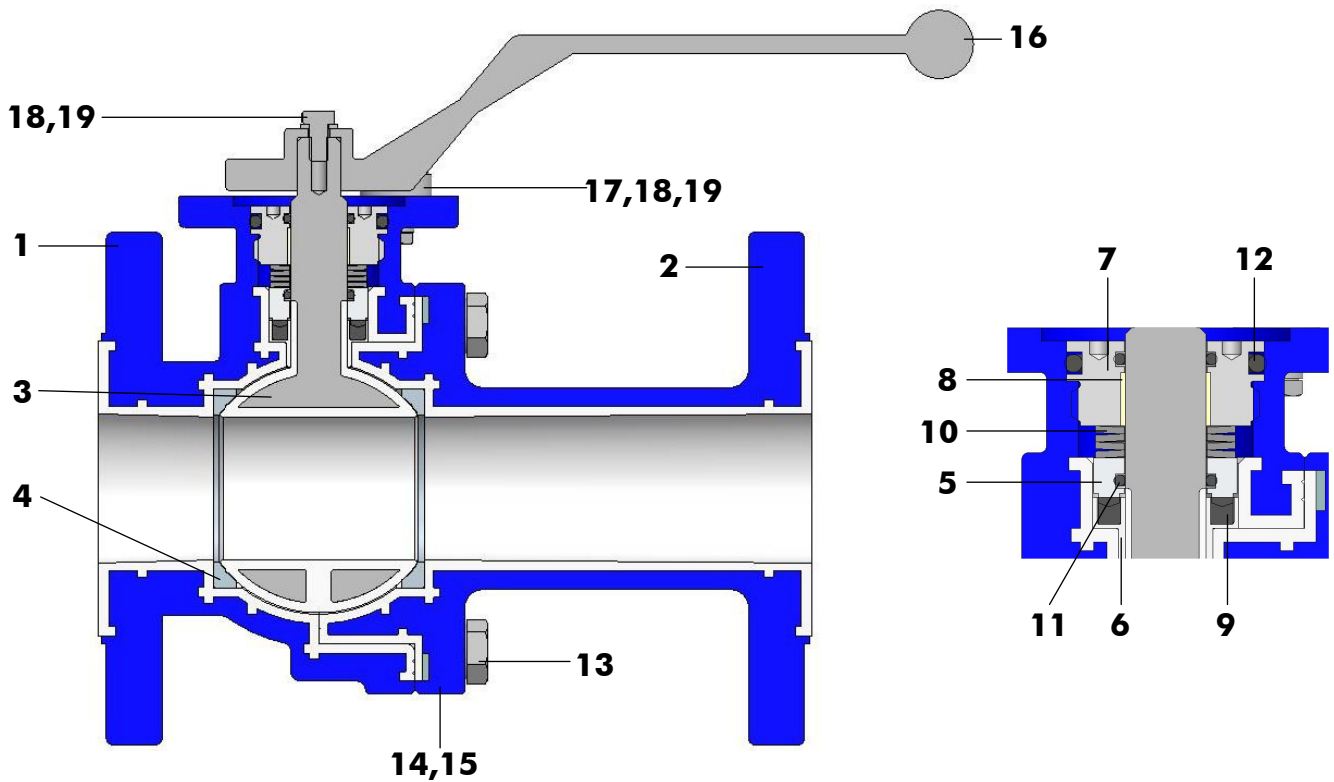

Item	Qty.	Description	Material Description	Material No. DIN 17440/41
1	1	Body Half Left, lined, RAL 5005	WCB/PFA	1.0619
2	1	Body Half Right, lined, RAL 5005	WCB/PFA	1.0619
3	1	Ball/Shaft one-piece, encapsulated	Duplex/PFA	1.4462
4	2	Ball Seat	PTFE	
5	1	Pressure Sleeve	SS316L	1.4404
6	1	Sealing Sleeve	PTFE	
7	1	Threaded Bushing	SS316L	1.4404
8	1	Bearing	C.Steel/PTFE	
9	1	Elastomer Insert	VMQ	
10	4	Belleville Spring	Spring Steel	1.8159
11	2	O-Ring	FPM	
12	1	O-Ring	FPM	
13	4	Hex. Head Cap Screw	A2-70	1.4310
14	1	Name Plate 42 x 14 CE	A2	1.4301
15	2	Hammer Screw 2.49 x 4.76	A2	1.4310
16	1	Handlever	SS304	1.4308
17	1	Stop	SS316L	1.4404
18	2	Hex. Head Cap Screw	A2-70	1.4310
19	2	Lock Washer	SS304	1.4310