

Inline Sampling Valves SIV Series DN15 – DN150 resp. ½" – 6"

for safe and representative sampling of corrosive, aggressive or even toxic media from pipelines, pressurized or at vacuum conditions – without process interruptions.

Modular Design

Sampling Valves SIV Series are available as DIN- or ANSI-valves, with handwheel as per standard. The valves are distinguished by its dead-space-free design as well as the extremely short outlet way for the representative sample.

The sturdy bodies are made of stainless steel casting 1.4408 (CF-8M) or optional with resistant linings and valve spindle encapsulations.



Main Features

- Bodies flanged or wafer-style, dead-space-free design, conforming to TA-Luft
- Safe and simple operation by standard handwheel, handwheel spring to close or with spring return deadman lever (fail safe close)
- Installation in any given position
- Corrosion-resistant materials, linings and encapsulations made of PFA or PFA-AS (conductive)
- Precision sampling for small sample volumes by valve spindle stroke adjustment
- Maintenance-free stuffing box or bellows seal
- Replaceable spindle gasket
- Face to face according to EN 558-1, range 1
- Variety by modular design

 **Conformity acc. to European Pressure Equipment Directive 97/23/EC (PED)**

Actuator Versions



Options / Accessories

- Bodies with heating jacket
- Needle adapter for lab bottle with septum
- Bottle support, adjustable
- Safety cabinet with inspection windows
- Flange versions: groove, PN40, ANSI 300lbs, clamp or with buttwelding ends
- Vertical adapter, sealing plug, activ. carbon filter
- Metal safety basket, with spring loaded plate
- Sampling collector, piston injector (syringe)
- Pneum. linear stroke actuator, single-acting FC

SIV: Technical Data, Construction

Operating Conditions

- Temperature range from -40°C (-40°F) up to +200°C (+392°F), depending on lining material
- Pressure range from 1 mbar (0.01 psi) up to 40 bar (580 psi), depending on size/pressure/temperature

Testing / Marking

- Pressure- and tightness testing acc. to EN 12266-1 (2012-06), leakage rate A, resp. API 598, 9th ed. (2009-09) as well as spark testing at 35 kV to assure lining integrity. Marking of valves on body and name plate acc. to EN 19.
- Material- resp. test certificates acc. to EN 10204-3.1/2.2/2.1

Construction of Valve

Body made of stainless steel casting 1.4408 (CF-8M) or with linings made of PFA or PFA-AS (anti-static), wall thickness min. 3 mm.
Flanges acc. to EN 1092 or ASME B16.5

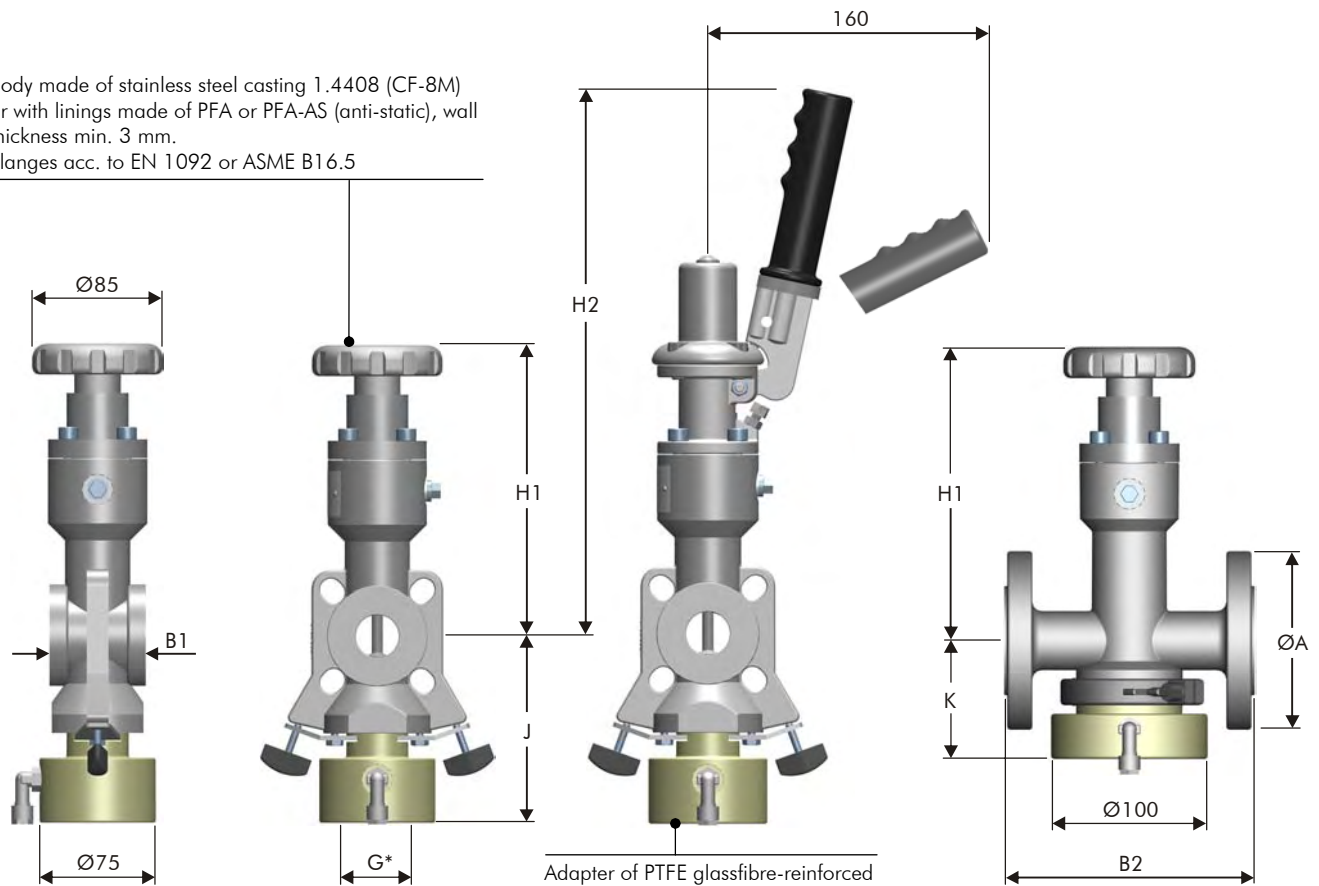

Technical Data

Dimensions in mm (lbs = kg x 2.2)

DN Size	ØA		B1	B2	B2	H1	H2	J	K	Wafer-style valve		Flanged valve	
	DIN	ANSI								DIN/ANSI	DIN	ANSI	kg Handwheel
15/1/2"	95	95	62	160	160	194	353	121	70	4.1	5.0	4.9	5.8
20/3/4"	98	98	62	160	160	194	353	121	70	4.1	5.0	4.9	5.8
25/1"	115	108	62	160	165	188	347	121	76	4.1	5.0	5.9	6.8
40/1 1/2"	150	127	62	200	165	196	355	128	83	4.7	5.6	8.1	9.0
50/2"	165	152	62	230	178	202	361	134	89	5.4	6.3	9.4	10.3
80/3"	200	190	62	310	203	229	388	148	103	5.9	6.8	14.6	15.5
100/4"	220	229	62	350	229	246	405	160	115	14.2	15.1	19.9	20.8
150/6"	285	279	62	480	267	264	429	185	138	20.5	21.4	28.5	29.4

Face to face B acc. to DIN EN 558-1 range 1 resp. range 3 and ASME B16.10 **G***: Standard threads for bottle GL45 or GL32 acc. to DIN 168-1
Weights for DIN valves only

Operating Conditions

- Temperature range from -40°C (-40°F) up to +200°C (+392°F), depending on lining material
- Pressure range from 1 mbar (0.01 psi) up to 40 bar (580 psi), depending on size/pressure/temperature

Testing / Marking

- Pressure- and tightness testing acc. to EN 12266-1 (2012-06), leakage rate A, resp. API 598, 9th ed. (2009-09) as well as spark testing at 35 kV to assure lining integrity. Marking of valves on body and name plate acc. to EN 19.
- Material- resp. test certificates acc. to EN 10204-3.1/2.2/2.1

Valves with Handwheel spring to close FC

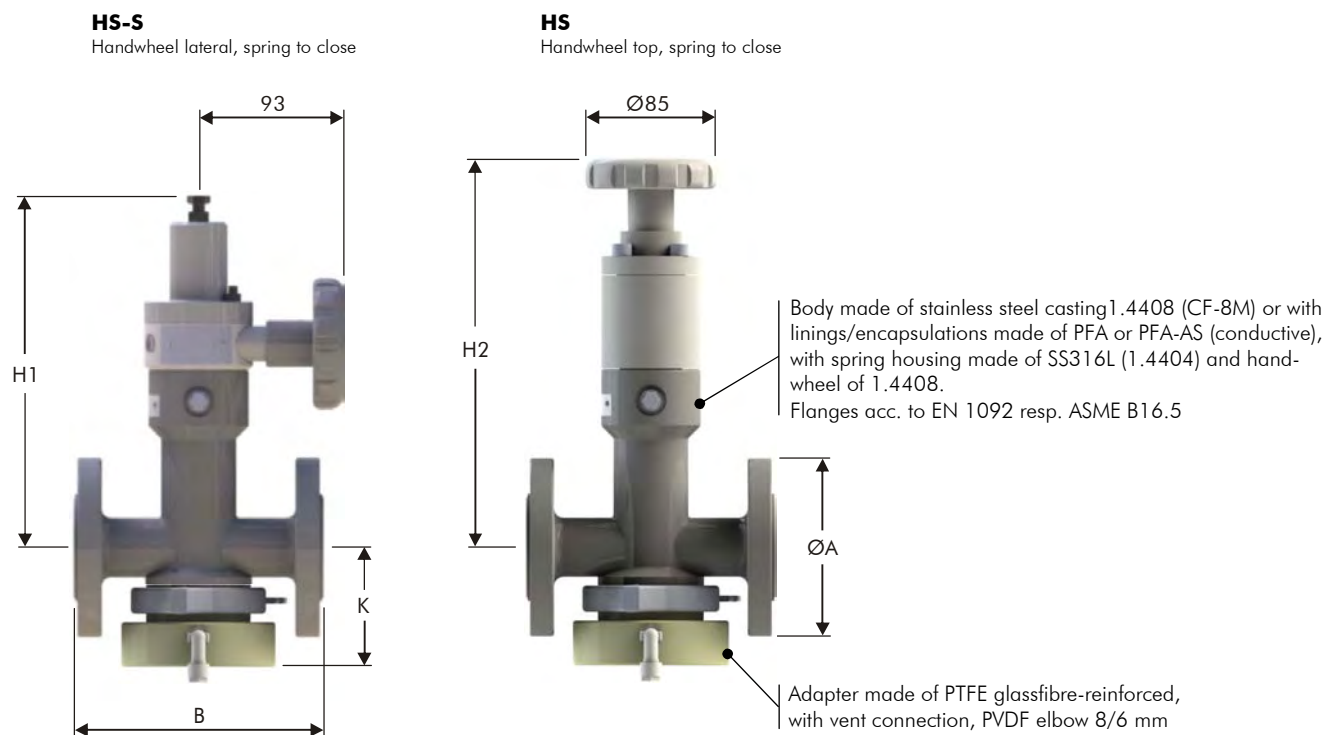

Technical Data Dimensions in mm (lbs = kg x 2.2)

DN Size nom.	ØA DIN	ØA ANSI	B DIN	B ANSI	H1 HS-S	H2 HS	K	Flanged valves		Wafer
								kg DIN	kg ANSI	kg
15/1/2"	95	95	160	160	246	255	70	6.8	6.8	5.2
20/3/4"	98	98	160	160	246	255	70	6.9	6.9	5.2
25/1"	115	108	160	165	240	249	76	7.8	7.9	5.2
40/1 1/2"	150	127	200	165	247	257	83	10.8	10.1	5.8
50/2"	165	152	230	178	254	263	89	11.8	10.6	6.5
80/3"	200	190	310	203	268	290	103	16.8	17.3	7.0
100/4"	220	229	350	229	280	307	116	22.3	21.1	15.3
150/6"	285	279	480	267	303	325	134	30.9	25.4	21.6

Face to face B acc. to DIN EN 558-1 range 1 resp. range 3 and ASME B16.10
 Standard threads for lab bottles GL45 or GL32 acc. to DIN 168-1

SIV: PT-Diagram, Function

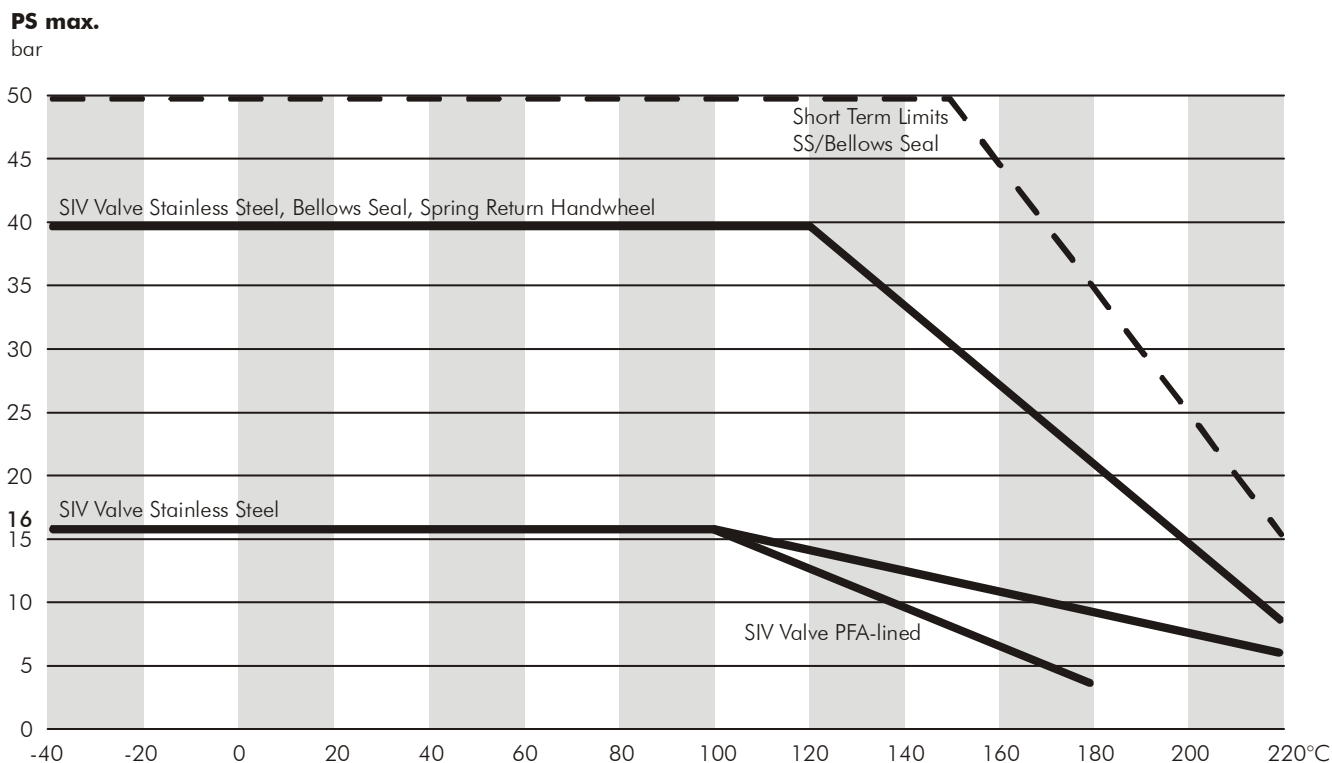

Operating Principle SIV Series (Sampling under pressure, with bottle)

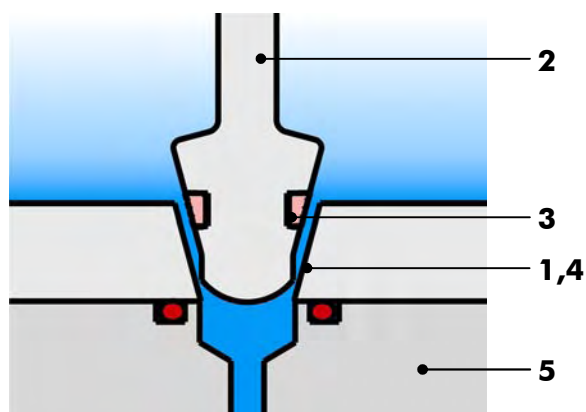

Manual Operation with handwheel or deadman lever

The valve is installed into pipeline either horizontally or vertically.

Media flows through the valve body (1) around the valve spindle (2), equipped with a resistant gasket (3).

By operating handwheel counter-clockwise (or lifting/pulling deadman lever), the valve spindle is lifted out of the tapered valve seat (4) and a representative sample will flow into the attached lab bottle. Trapped air inside the bottle escapes through the vent connection of the adapter (5), sealed by a FEP-encapsulated O-ring.

When the bottle contains the required sample volume, the handwheel is now operated clockwise, which in turn pushes the valve spindle back into the valve seat.

The valve is 100% dead-space-free again.

Valves with Collector (SC) or Piston Injector (PI)

For critical and heavy duty applications, a sampling collector or a piston injector is used in place of the standard adapter with lab bottle.

Available with outlet nozzle/safety cap and lab holder.

SIV-SC: Technical Data, Valve with Collector

Operating Conditions

- Temperature range from -40°C (-40°F) up to +200°C (+392°F)
- Pressure range from 1 mbar (0.01 psi) up to 16 bar (232 psi)

Testing / Marking

- Pressure- and tightness testing acc. to EN 12266-1 (2012-06), leakage rate A, resp. API 598, 9th ed. (2009-09). Marking of valves on body and name plate acc. to EN 19.
- Material- resp. test certificates acc. to EN 10204-3.1/2.2/2.1

Wafer-style Valve with Collector

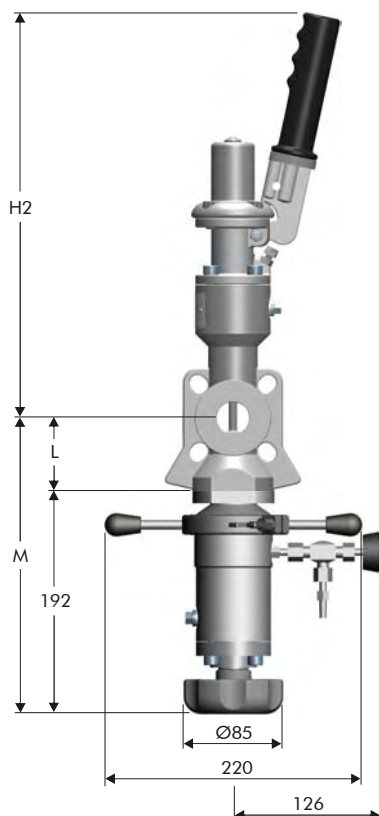

Description

- Wafer-style valve compl. made of stainless steel 1.4408/1.4404, with deadman lever, for horizontal or vertical installation between flanges acc. to EN 1092 or ASME B16.5
- Collector compl. made of stainless steel SS316L, handwheel 1.4408, incl. SS needle valve and safety plug made of PP (option), sampling volume standard approx. 100 ml (3.4 oz)

Technical Data Dimensions in mm (lbs = kg x 2.2)

DN Size nom.	H2	L	M	kg compl.
25/1"	347	63	255	7.6
40/1½"	355	71	263	8.2
50/2"	361	77	269	8.9
80/3"	388	91	283	9.6
100/4"	405	103	295	17.8
150/6"	429	127	319	24.0

special executions upon request

Operating Conditions

- Temperature range from -40°C (-40°F) up to $+200^{\circ}\text{C}$ ($+392^{\circ}\text{F}$)
- Pressure range from 1 mbar (0.01 psi) up to 10 bar (145 psi)

Testing / Marking

- Pressure- and tightness testing acc. to EN 12266-1 (2012-06), leakage rate A, resp. API 598, 9th ed. (2009-09). Marking of valves on body and name plate acc. to EN 19.
- Material- resp. test certificates acc. to EN 10204-3.1/2.2/2.1

Flanged Valve with Piston Injector

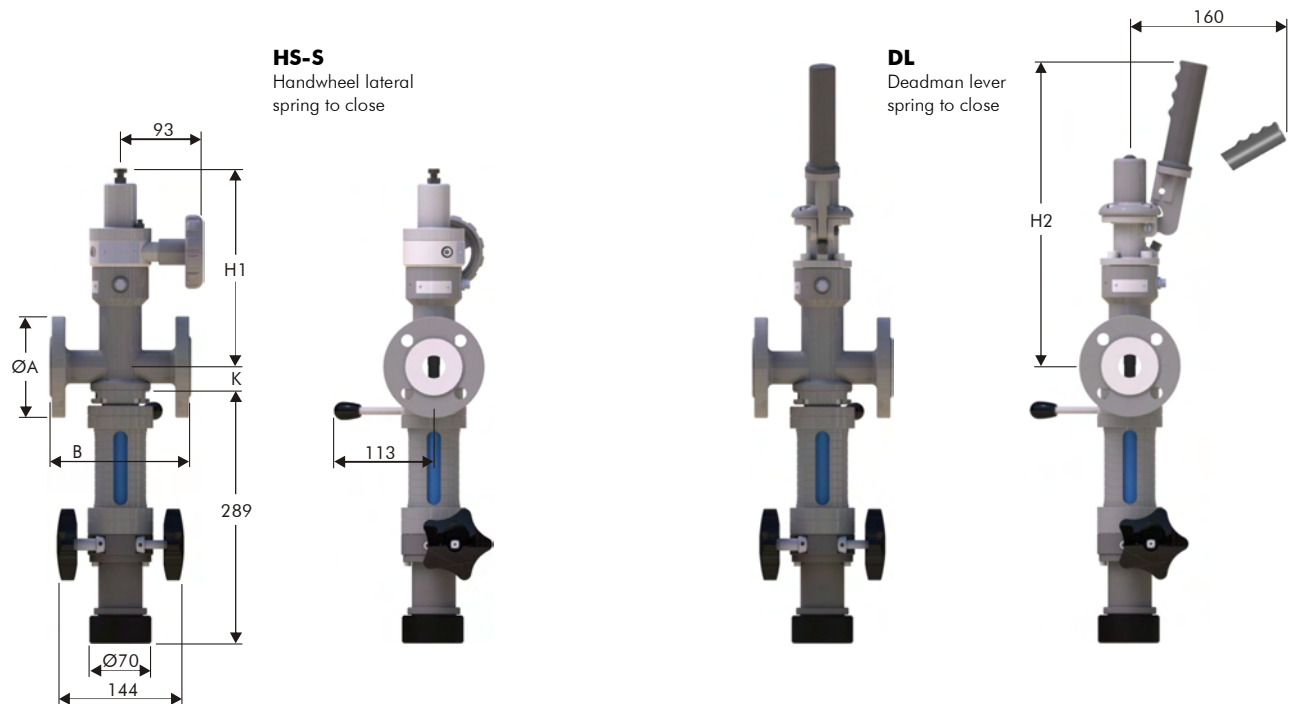

Description

- Flanged valve unit made of stainless steel 1.4408(CF-8M)/1.4404 or PFA-lined, with spring return handwheel lateral (optional with deadman lever), for horizontal or vertical installation between flanges acc. to EN 1092 or ASME B16.5
- Syringe unit made of stainless steel, PFA-lined, with Borosilicate glass cylinder. Standard sampling volume 100 ml (3.4 oz)

Technical Data

Dimensions in mm (lbs = kg x 2.2)

DN	A	A	B	B	H1	H2	K	kg	kg
Size nom.	DIN	ANSI	DIN	ANSI				DIN	ANSI
15/1/2"	95	95	160	160	246	353	27	8.0	8.0
20/3/4"	105	105	160	160	246	353	27	8.0	8.0
25/1"	115	108	160	165	240	347	33	9.0	9.2
40/1 1/2"	150	127	200	165	247	355	40	11.2	10.5
50/2"	165	152	230	178	254	361	47	12.5	11.5
80/3"	200	190	310	203	268	388	61	17.7	15.0
100/4"	220	229	350	229	280	405	73	23.0	21.0
150/5"	285	279	480	267	303	429	96	31.6	27.0
200/6"	340	343	600	292	328	454	121	50.0	45.0

- Face to face B acc. to DIN EN 558-1 range 1 resp. range 3 and ASME B16.10
- other materials, sizes and volumes on request

SIV: Parts List Valve compl., SS-Sb, manual

83 Inline Sampling Valves, stainless steel

PM 83 M.05 e

June 2013

Standard Version (Picture showing DN 25 PN16/1"-150lbs, Wafer stainless steel, stuffing box, with handwheel)



Main Components

Item	Qty.	Description	Materials	No.
1	1	DN 25 PN16/1"-150lbs Wafer (optional flanged body)	CF-8M	1.4408
2	1	Handwheel unit HW standard (optional type HS, spring to close)	CF-8M/SS316L	1.4408/1.4404
3	1	Valve Spindle	SS316L	1.4404
4	1	Spindle Seal, grooved	Valflon	
5	2	Spacer 6 mm	SS316L	1.4404
6	2	Seal Ring	PTFE-T	
7	1	Spacer 18 mm	SS316L	1.4404
8	1	Pressure Ring	SS316L	1.4404
9	1	Lantern	SS316L	1.4404
10	1	Rotating Stop	SS316L	1.4404
11	1	Belleville Spring	Spring Steel	1.8159
12	1	Bearing GSM	Polymer	
13	1	O-Ring	FPM	
14	1	X-Ring	FPM	
15	2	Wing Nut compl., with SS Clamp and Hex. Screws	PA-GF/SS304	
16	1	Bottle Adapter	PTFE-R	
17	1	O-Ring (bottle adapter)	FEP/FPM	
18	1	Elbow 90° (vent connection)	PVDF	

SIV: Parts List Valve compl., SS_Bs, manual

83 Inline Sampling Valves, stainless steel

PM 83 M.06 e

June 2013

Standard Version (Picture showing DN 25 PN16/1"-150lbs, Wafer stainless steel, bellows seal, with handwheel)



Main Components

Item	Qty.	Description	Materials	No.
1	1	DN 25 PN16/1"-150lbs Wafer (optional flanged body)	CF-8M	1.4408
2	1	Handwheel unit HW standard (optional type HS, spring to close)	CF-8M/SS316L	1.4408/1.4404
3	1	Valve Spindle Front HW	SS316L	1.4404
4	1	Spindle Seal, grooved	Valflon	
5	1	Spindle Shaft Bs HW	SS316L	1.4404
6	1	O-Ring	FFPM	
7	1	Bellow compl.	SS316Ti	1.4571
8	1	Gasket	Graphite	
9	1	Lantern	SS316L	1.4404
10	1	Rotating Stop	SS316L	1.4404
11	1	Bearing GSM	Polymer	
12	1	O-Ring	FPM	
13	1	X-Ring	FPM	
14	2	Wing Nut compl., with SS Clamp and Hex. Screws	PA-GF/SS304	
15	1	Bottle Adapter	PTFE-R	
16	1	O-Ring (bottle adapter)	FEP/FPM	
17	1	Elbow 90° (vent connection)	PVDF	

SIV: Parts List Valve compl., PFA_Sb, manual

83 Inline Sampling Valves, plastomer-lined

PM 83 M.07 e

June 2013

Standard Version (Picture showing DN 25 PN16, Flanged, PFA-lined, stuffing box, with deadman lever, spring to close)

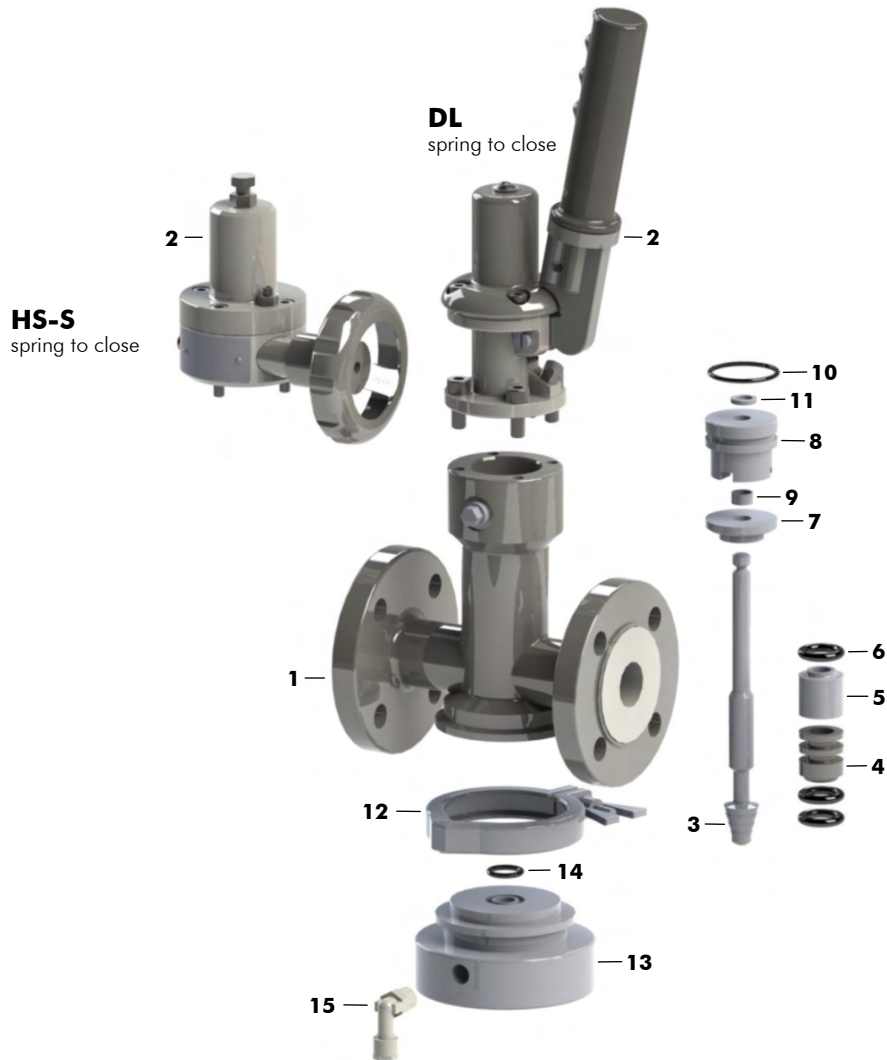

Main Components

Item	Qty.	Description	Materials	No.
1	1	DN 25 PN16 Flanged, PFA-lined (optional wafer-style body)	CF-8M/PFA	1.4408
2	1	Deadman Lever unit DL standard (optional handwheel HS-S, spring to close)	CF-8M/SS316L	1.4408/1.4404
3	1	Valve Spindle DL, PFA-encapsulated	SS316L/PFA	1.4404
4	1	Packing	PTFE/Glass/MoS2	
5	1	Pressure Sleeve	PVDF	
6	3	O-Ring	FPM	
7	1	Pressure Ring	SS316L	1.4404
8	1	Lantern	SS316L	1.4404
9	1	Bearing GSM	Polymer	
10	1	O-Ring	FPM	
11	1	X-Ring	FPM	
12	1	Clamp	SS304	1.4301
13	1	Bottle Adapter	PTFE-R	
14	1	O-Ring (bottle adapter)	FEP/FPM	
15	1	Elbow 90° (vent connection)	PVDF	

