

Kugleventil type UNI-S83/84

DN8 - 50

PN55



PED 97/23/EC — modul D1 kategori I, II

Beskrivelse

UNI-S83/84, 3- og 4-vejs kugleventil med ISO-topflange kan serviceres uden at skille rørene ad. Ved normale 3- og 4-vejsventiler skal rørene trækkes ud eller skilles ad for at få ventilhuset ud. UNI-S83/84 med **in-line service** kan huset tages ud uden dette er nødvendigt.

UNI-S83/84 fås som T-/L-/X- eller I-ventil. Den er forsynet med ISO-topflange for direkte montage af aktuator.

UNI-S83/84 har 4 sæder som hjælper til at holde kuglens position stabil. 4 inspektionshuller ved ISO-toppen tillader mediet at flyde ud ved lækage omkring spindlen. Dette vil beskytte aktuatoren samt holde temperaturen nede mellem ventil og aktuator.

UNI-S83/84 kan også forsynes med "cavity filler" for at forhindre hulrummet bagved kuglen i at fyldes op.

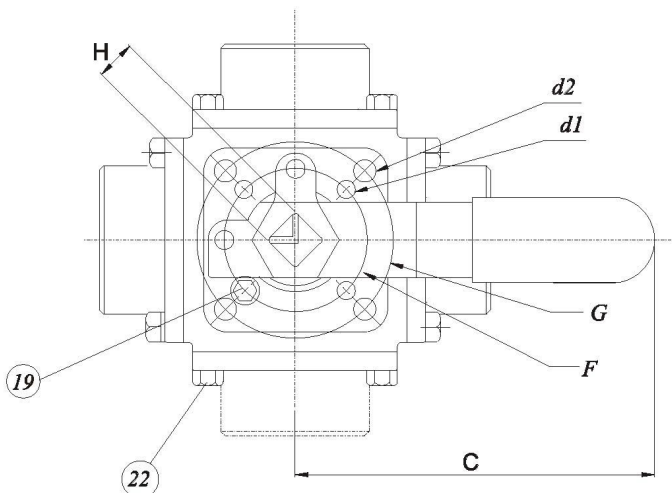

Uni-Valve A/s
VENTILER & INSTRUMENTER



Specifikation

- ⇒ Hus og endestykker voksstøbt
- ⇒ **In-line service**
- ⇒ Stål og rustfrit stål
- ⇒ ISO 5211 top-flange
- ⇒ Justerbar spindelpakning
- ⇒ Udblæsningssikker spindel
- ⇒ L- T- X- eller I-boret
- ⇒ Testet under vand ved 80-100 psi
- ⇒ Temperatur fra -29 - +232 degC
- ⇒ Tilslutninger: gevind og/eller svejseender
- ⇒ Låsemekanisme

Optioner

- ⇒ Aktuator
- ⇒ PTFE / PFA coating (40-70 µm)
- ⇒ PEEK sæde og pakning
- ⇒ Cavity fillar
- ⇒ Hastelloy C, Alloy 20, Duplex, Monel 400
- ⇒ Fire-safe design

Kugleventil type UNI-S83/84

DN8 - 50

PN55

Uni-Valve A/s
VENTILER & INSTRUMENTER



Uni-Valve A/S—Sydvestvej 138-140—2600 Glostrup—Danmark

mail@uni-valve.com—www.uni-valve.com

Tel.: +45 43 43 82 00—Fax: +45 43 43 74 75

Materialer og mål DN8 - DN50 (1/4" - 2")

Pos.	Del	Materiale
1	endestykker	AISI316
1A	sædeholder	AISI316
1B	huspakning	PTFE
2	pakning	PTFE
3	hus	AISI316
4	kugle	AISI316
5	sæder	PTFE
6	spindel	AISI316
7	ned. spindelpakning	RPTFE
8	O-ring	VITON
9	Øv. spindelpakning	PTFE
10	bøsning	AISI304
11	tallerkenfjedre	AISI301
12	spindelmøtrik	AISI304
13	Lock-cap	AISI304
14	afstandskive	AISI304
15	Stop plade	AISI304
16	håndtag møtrik	AISI304
17	håndtag	AISI304
18	greb	plastik
19	stop bolt	AISI304
20	styre tap	AISI316
21	stop bolt møtrik	AISI304
22	bolte	AISI304

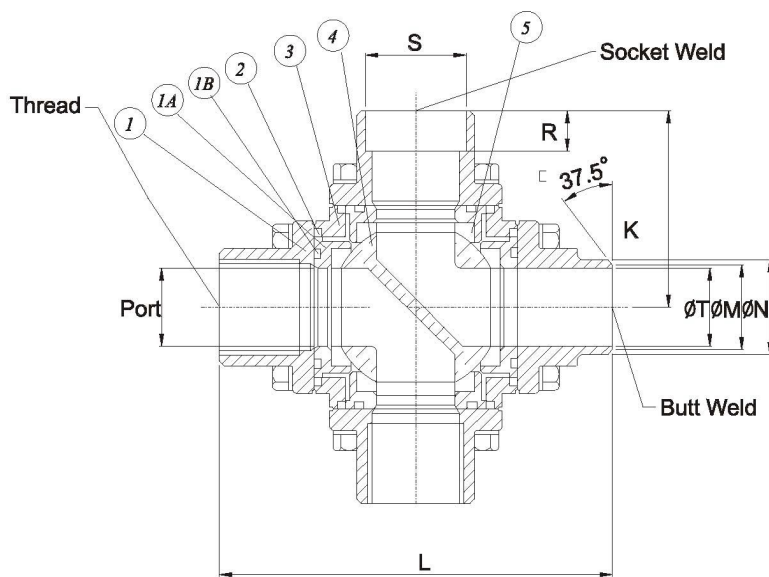
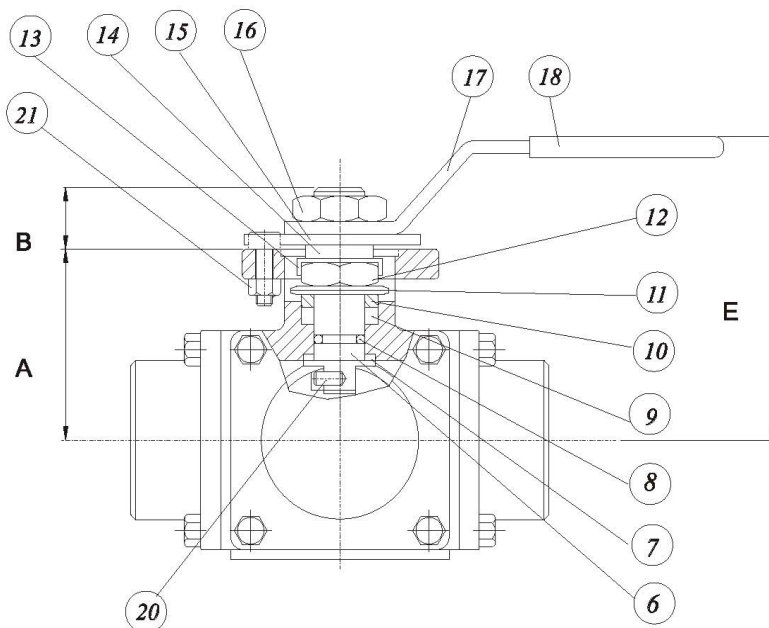

DN	A	B	C	d1	d2	E	F	G	H	K	L	R	S	T	M	N	Port	vægt
DN8 (1/4")	38.5	11	130	6.0	6.0	62	36	42	9	44	88	11.1	14.2	10	12.5	17.5	10	1.4
DN10 (3/8")	38.5	11	130	6.0	6.0	62	36	42	9	44	88	11.1	17.5	12	14.5	20	12.5	1.4
DN15 (1/2")	41	11	130	6.0	6.0	64	36	42	9	52.5	105	12.7	21.7	15	17.5	22.5	15	2.1
DN20 (3/4")	49	14	165	6.0	7.1	82	42	50	11	52.5	112	14.3	27.1	20	22.5	28.5	20	2.9
DN25 (1")	55	14	165	6.0	7.1	89	42	50	11	64	128	15.9	33.9	25	28	34.5	25	4.0
DN32 (1 1/4")	63	18	205	7.1	9.2	98	50	70	14	70	140	17.5	42.5	32	35	43.5	32	5.9
DN40 (1 1/2")	74	18	205	7.1	9.2	108	50	70	14	80	160	19.1	48.6	38	41	49.5	38	9.3
DN50 (2")	93	23	325	9.2	11.4	140	70	102	17	96	192	22.2	61.1	50	54	61.5	50	16.6

Kugleventil type UNI-S83/84

DN8 - 50

PN55

Uni-Valve A/s
VENTILER & INSTRUMENTER



Eksploderet tegning

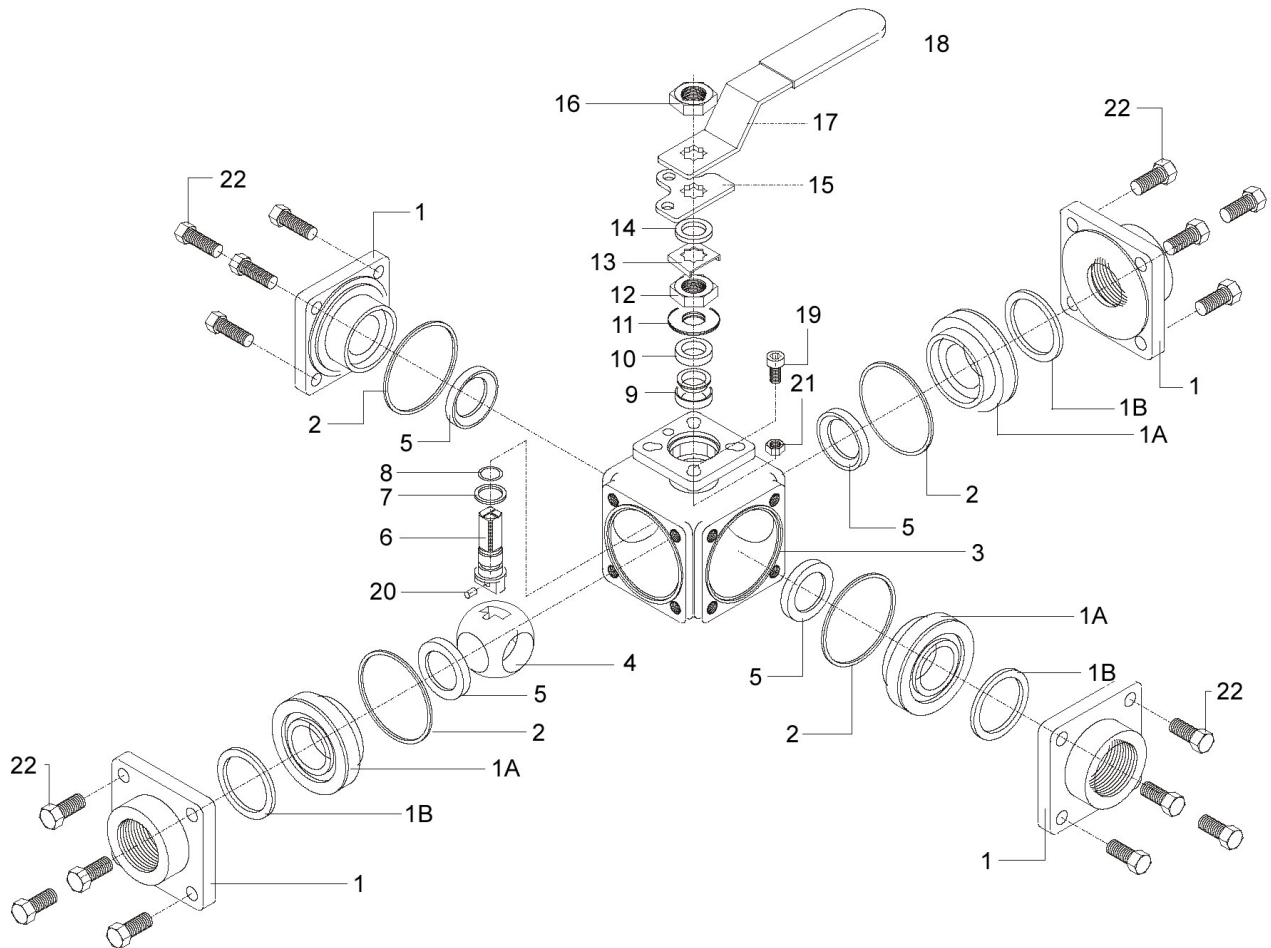

Uni-Valve A/S — Sydvestvej 138-140 — 2600 Glostrup — Danmark

mail@uni-valve.com — www.uni-valve.com

Tel.: +45 43 43 82 00 — Fax: +45 43 43 74 75

Kugleventil type UNI-S83/84

DN65 - 100

PN55

Uni-Valve A/s
VENTILER & INSTRUMENTER



Uni-Valve A/S — Sydvestvej 138-140 — 2600 Glostrup — Danmark

mail@uni-valve.com — www.uni-valve.com

Tel.: +45 43 43 82 00 — Fax: +45 43 43 74 75

Materialer og mål DN65 - DN100 (2 1/2" - 4")

Pos.	Del	Materiale
1	endestykker	AISI316
2	hus	AISI316
3	kugle og spindel	AISI316
4	leje	PTFE + AISI316
5	sæder	PTFE
6	Pakning	PTFE
7	O-ring	VITON
8	spindelpakning	PTFE
9	bøsning	AISI304
10	tallerkenfjedre	AISI301
11	Bøsning	AISI304
12	Håndtag holder	A351 CF8
13	stop bolt møtrik	AISI304
14	Håndtag møtrik	AISI304
15	håndtag	stålrør
16	Endedæksel	AISI316
17	bolt	AISI304
18	Bolte endestykker	AISI304
19	møtrikker	AISI304
20	Stop bolt	AISI316
21	Overdel hus	AISI304
22	pakning	PTFE
23	sædeholder	AISI316
24	huspakning	PTFE

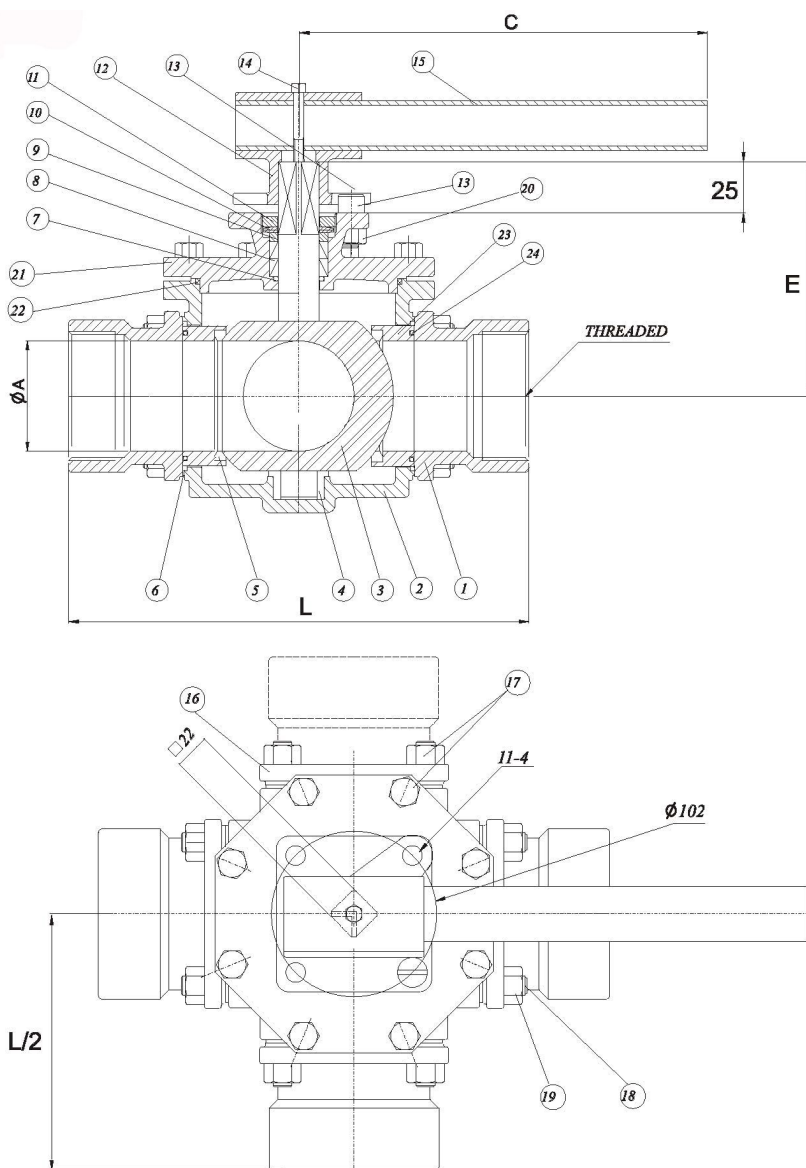

DN	A	B	C	E	L	L (BW)	H	S	T	M	N	Vægt 3-vejs	Vægt 4-vejs
DN65 (2 1/2")	62	65	400	144	294	265	22.2	73.9/77 (DIN)	65	70	78	22.9	23.8
DN80 (3")	76	80	500	162	317	291	25.4	89.6	80	85	94	31.6	32.2
DN100 (4")	96	100	650	182	369	345	32	115	100	100	117.5	54	54.8

Kugleventil type UNI-S83/84

DN65 - 100

PN55

Uni-Valve A/s
VENTILER & INSTRUMENTER



Eksploderet tegning

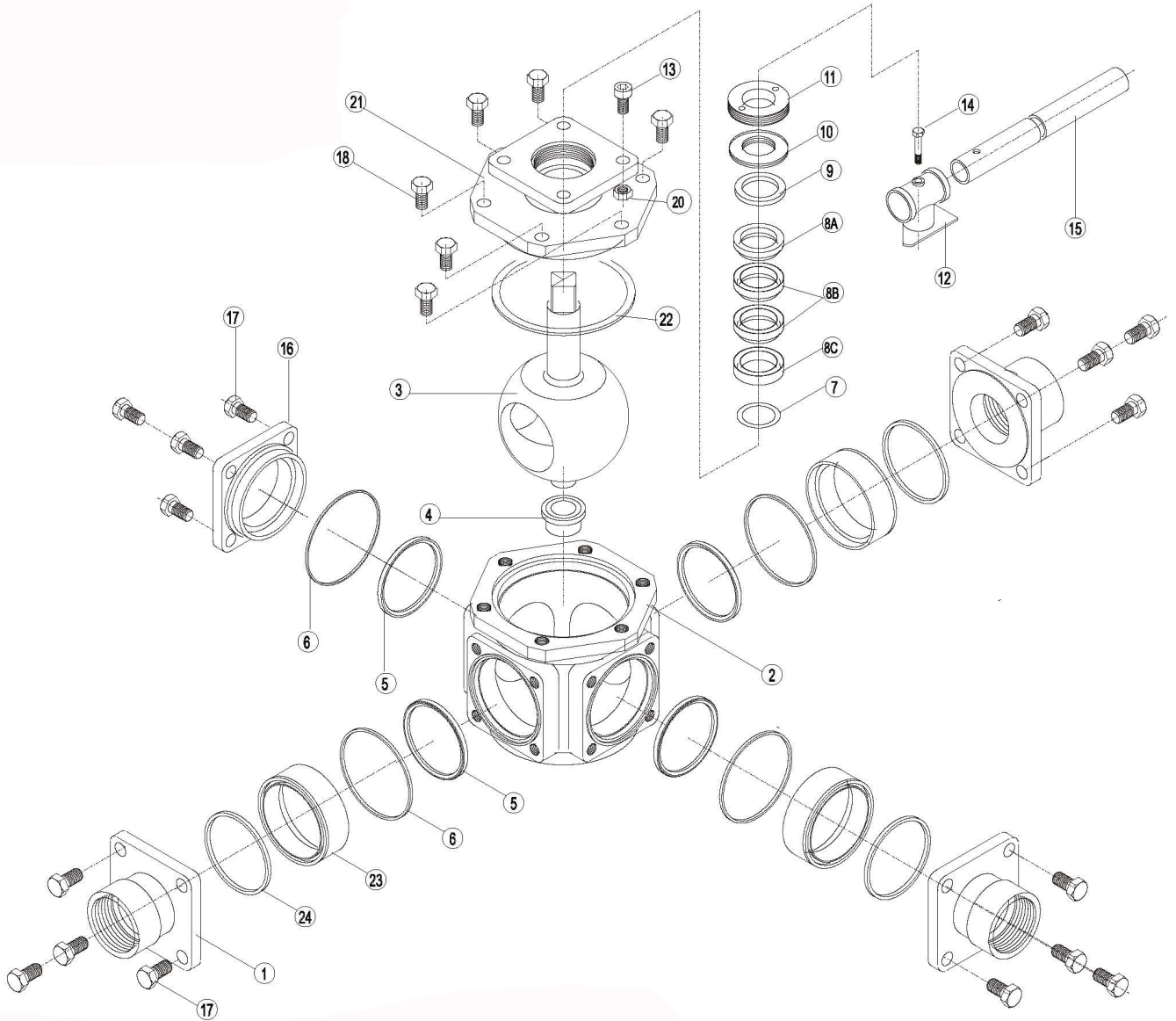

Uni-Valve A/S — Sydvestvej 138-140 — 2600 Glostrup — Danmark

mail@uni-valve.com — www.uni-valve.com

Tel.: +45 43 43 82 00 — Fax: +45 43 43 74 75

Kugleventil type UNI-S83/84

DN8 - 100

PN55

Uni-Valve A/s
VENTILER & INSTRUMENTER



Uni-Valve A/S — Sydvestvej 138-140 — 2600 Glostrup — Danmark

mail@uni-valve.com — www.uni-valve.com

Tel.: +45 43 43 82 00 — Fax: +45 43 43 74 75

Flowmønster

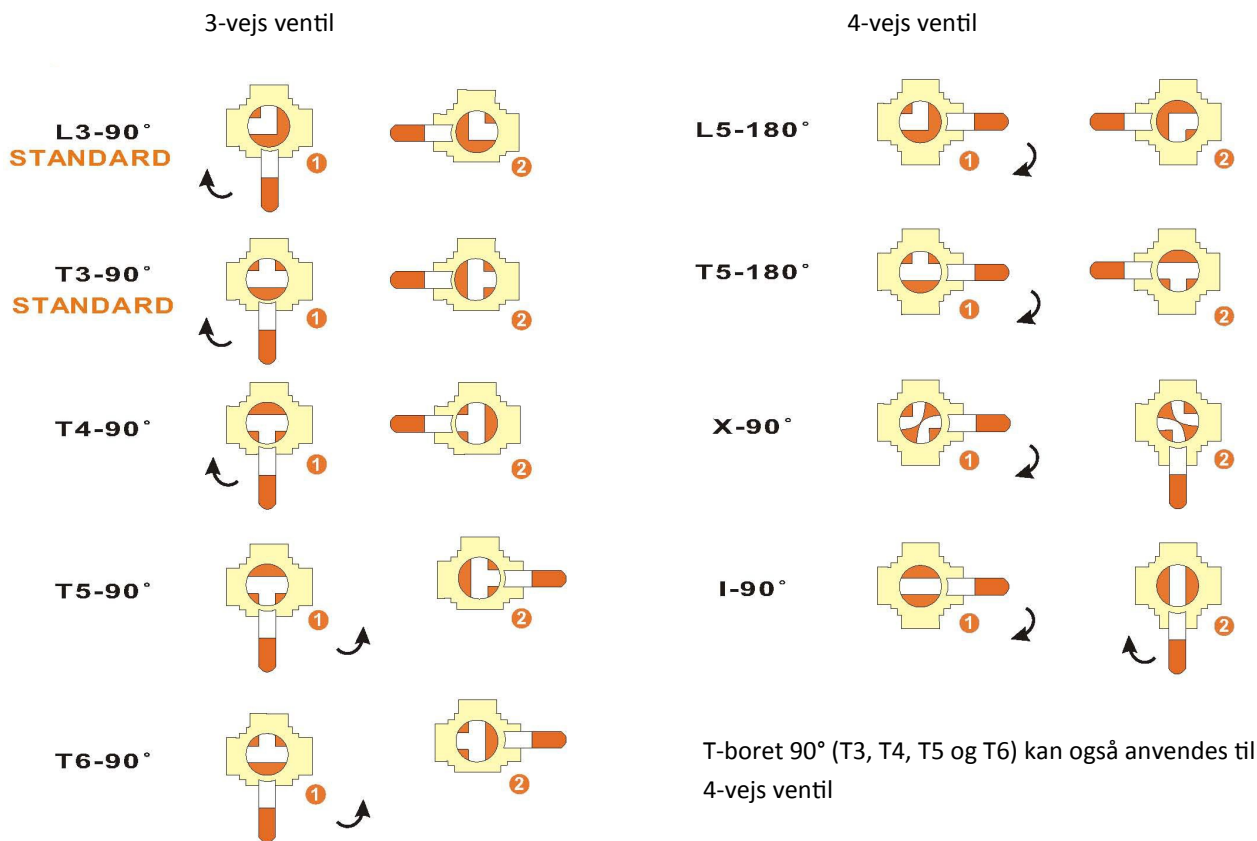

Tryk / temperatur

