

Control Valve 8044

with integrated positioner GS 1 series, DN 15 up to DN 100



Pneumatic control valve with integrated p/p- or i/p- positioner and pneumatic control valve with integrated microprocessor positioner for control of neutral and aggressive fluids in process engineering, chemical industry and for plant equipment.

- Space saving design and low weight
- Fast response due to short strokes
- High Kvs- (Cv)- values
- Tight shut- off even at higher temperatures
- No exposed moving parts
- No steady- state air consumption
- Operation independent of mounting position and supply pressure variations
- Not sensitive to vibration
- Instrument grade air not essential
- Software configurable flow characteristics
- Protection Class IP65



Technical Information

Body design	flangeless, wafer-type construction dimensions acc. DIN EN 558-1 series 20 for flanges acc. DIN EN 1092-1 form B		
Nominal sizes	DN 15 to DN 100		
Nominal pressure	PN 40 according DIN 2401, also for flanges PN 10 - PN 25		
Fluid temperature	body 1.0619	-10°C to +230°C	
	body 1.4571	-60°C to +230°C	
Ambient temperature*	-30°C up to +100°C		
Rangeability / Characteristic analog positioner	25 : 1		
digital positioner	30 : 1		
Leakage	Disc pair Carbon-stainless steel	Disc pair SFC	Disc pair STN 2
% of Kvs	< 0,0001	< 0,0005	< 0,001
IEC 60534-4	IV-S1	IV-S1	IV
EN 12266-1	D	E	E

* Please consider the limitation of use of the positioner!



Kvs-values see data sheet 8001.

Materials

Body	carbon steel 1.0619	stainless steel 1.4581	
Tube for packing intermediate piece	stainless steel 1.4571/1.4581		
Bonnet	brass, chrome-plated (actuator Ø 80 mm), aluminium KTL-coated, (actuator Ø 125 mm)		
Actuator springs	stainless steel 1.4310 (actuator Ø 80 mm); spring steel wire C, plastic coated (actuator Ø 125 mm)		
Packing	PTFE carbon filled (spring 1.4310)		
Actuating stem	stainless steel 1.4571, roller burnished		
Bellows	stainless steel 1.4571		
Fixed disc	stainless steel 1.4581, coated	SFC - disc	STN2 - disc
Sliding disc	special carbon material	SFC - disc	STN2 - disc
Coupling ring for disc	stainless steel 1.4581		
Window for positioner indicator	PA Trogamid (clean)		

Positioner

For technical information of our positioners please refer to the corresponding data sheets.

Control Valve 8044-GS1

with integrated positioner



Admissible differential pressure
(For temperatures of up to 120°C)

For temperatures of 120°C and above: obey application limits !

p/p- und i/p-Stellungsregler, Typ 8047

Disc-pair: carbon - stainless steel coated
SFC - stainless steel coated

Disc pair: STN2

DN	actuator	max. differential pressures		pilot pressures
		control	on/off	
15	80	40	40	3,0 - 6
20	80	37	37	3,5 - 6
25	80	29	31	3,5 - 6
32	80	21	25	4,0 - 6
40	80	14	19	4,0 - 6
50	80	8	12	4,5 - 6
65	80	7	10	4,5 - 6
80	80	4	6	4,5 - 6
100	80	2,5	4	4,5 - 6
15	125	40	40	3,0 - 6
20	125	40	40	3,0 - 6
25	125	40	40	3,0 - 6
32	125	40	40	3,0 - 6
40	125	34	40	3,0 - 6
50	125	20	27	3,5 - 6
65	125	16	23	3,5 - 6
80	125	10	14	3,5 - 6
100	125	6	9	3,5 - 6

DN	actuator	max. differential pressures		pilot pressures
		control	on/off	
15	80	28	30	3,5 - 6
20	80	19	23	4,0 - 6
25	80	13	17	4,0 - 6
32	80	9	13	4,0 - 6
40	80	5,5	8	4,0 - 6
50	80	3	5	4,5 - 6
65	80	2,5	4	4,5 - 6
80	80	-	-	-
100	80	-	-	-
15	125	40	40	3,0 - 6
20	125	40	40	3,0 - 6
25	125	30	38	3,0 - 6
32	125	21	28	3,0 - 6
40	125	13	19	3,0 - 6
50	125	7	11	3,5 - 6
65	125	6	9	3,5 - 6
80	125	3,5	5	3,5 - 6
100	125	2	3	3,5 - 6

digital positioner, Type 8049 (also on-off valves and valves with other side-mounted positioner)

Disc-pair: carbon - stainless steel coated
SFC - stainless steel coated

Disc pair: STN2

DN	actuator	max. differential pressures	pilot pressures
		control, on/off	
15	80	40	3,5 - 6
20	80	40	3,5 - 6
25	80	40	3,5 - 6
32	80	40	4,0 - 6
40	80	30	4,0 - 6
50	80	19	4,5 - 6
65	80	16	4,5 - 6
80	80	10	5,0 - 6
100	80	6	5,0 - 6
15	125	40	3,0 - 6
20	125	40	3,0 - 6
25	125	40	3,0 - 6
32	125	40	3,0 - 6
40	125	40	3,0 - 6
50	125	40	3,5 - 6
65	125	37	3,5 - 6
80	125	23	4,0 - 6
100	125	14	4,0 - 6

DN	actuator	max. differential pressures	pilot pressures
		control, on/off	
15	80	40	3,5 - 6
20	80	37	4,0 - 6
25	80	27	4,0 - 6
32	80	20	4,5 - 6
40	80	13	4,5 - 6
50	80	8	5,0 - 6
65	80	6	5,0 - 6
80	80	3,5	5,0 - 6
100	80	2	5,0 - 6
15	125	40	3,0 - 6
20	125	40	3,0 - 6
25	125	40	3,0 - 6
32	125	40	3,5 - 6
40	125	27	3,5 - 6
50	125	18	4,0 - 6
65	125	15	4,0 - 6
80	125	9	4,0 - 6
100	125	5,5	4,0 - 6

Control Valve 8044-GS1

with integrated positioner



Applications limits for GS1-Valves made of stainless steel

PN 40

DN	Sliding unit: carbon/SFC - stainless steel, coated max. admissible pressures for GS1-valves						Sliding unit: carbon - STN2 max. admissible pressures for GS1-valves					
	100°C	150°C	200°C	250°C	300°C	350°C	100°C	150°C	200°C	250°C	300°C	350°C
15 - 25	40	38	34	33	31	29	40	38	34	33	31	29
32	40	38	34	33	31	29	40	38	34	31	25	22
40	40	38	34	33	31	29	27	25	24	19	16	14
50	40	38	34	33	31	29	40	38	34	33	28	24
65	40	38	34	33	31	29	37	35	33	27	22	19
80	40	38	34	31	26	23	22	21	20	16	13	11
100	24	23	22	19	16	14	13	12	12	10	8,0	7,0

Limitation for valves in carbon steel and SFC-sliding discs: 300°C

Control Valve 8044-GS1

with integrated positioner



Ordering Number System

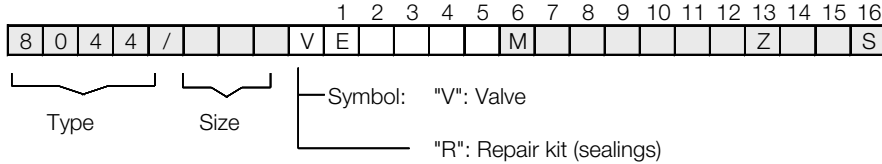

1 - 5 : Please quote all 5 sections
6 - 12: Quote only if required

1. Type	2. Connection	3. Body material	4. Safety position	5. Actuator	6. Special versions	7. Springs	8. Stem sealing
E GS piston control valve type 8044 (short version)	0 flangeless wafertype construction for flanges acc. DIN 2632-2635 (PN10-PN40)	0 carbon steel 1.0619 1 stainless steel 1.4571/1.4581 2 carbon steel 1.0619 reduced design stainless steel 3 1.4581 reduced design	0 spring closes 1 spring opens	1 piston 80 mm 2 piston 125 mm	M state, if further sections are quoted	- standard	- PTFE-packing, self adjusting (standard)

9. Moving disc	10. Fixed disc	11. Kvs-values	12. Characteristic	13. Accessories	14. Positioner	15. Special versions	16. Further special versions
- carbon material 9 STN2/STN3-disc S SFC-disc	- stainless steel 1.4571, coated 1 STN2-disc (only in combination with pos. "9") 3 STN3-disc (only in combination with pos. "9")	- 100% (Stand.) A red. to 63% 1 red. to 40% B red. to 25% 2 red. to 16% C red. to 10% 3 red. to 6,3% 4 red. to 2,5% 5 red. to 1% 6 red. to 20% 7 red. to 12% 8 red. to 2% 9 red. to 0,4%	- linear equal percentage 1	Z Accessories	2 p/p-positioner Type 8047 + pos.indic. 3 i/p-positioner Type 8047 + pos.indic. 5 i/p-positioner Type 8047 + pos.indic. Eex ibll CT6, with plug conn. M12x1 8 i/p-positioner Type 8047 + pos.indic. plug conn. M12x1 C digital positioner Type 8049, 4-wire R digital positioner Type 8049, 2-wire T digital positioner Type 8049, AS-i version W digital positioner Type 8049, 2-wire ex-version	1 fittings and tubing made from PA E fittings and tubing made of stainless steel	S further special versions

Ordering example: 8044/050VE0101M - - - - 2-ZC
 GS-Control valve type 8044, short design, DN 50, PN 10/40, body stainless steel, spring closes, actuator 80 mm, PTFE-V-shaped sealing rings, moving disc carbon material, fixed disc stainless steel, Kvs-value 16% (red.) seat characteristic linear, digital positioner Type 8049 4-wire

Control Valve 8044-GS1

with integrated positioner

Dimensions and Weights

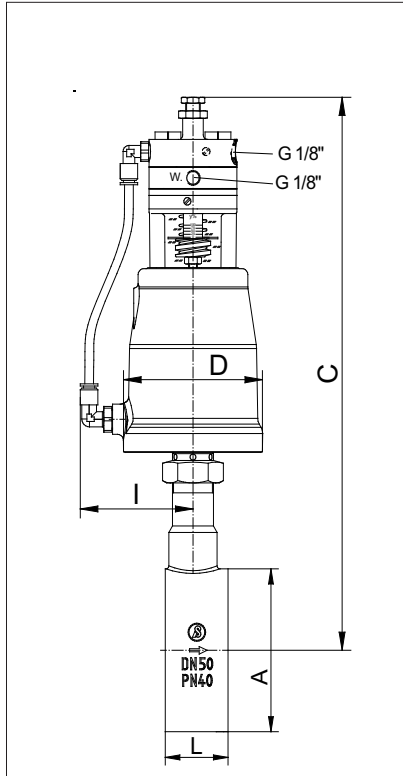

Type 8044 with p/p-positioner
Type 8047
with position indicator

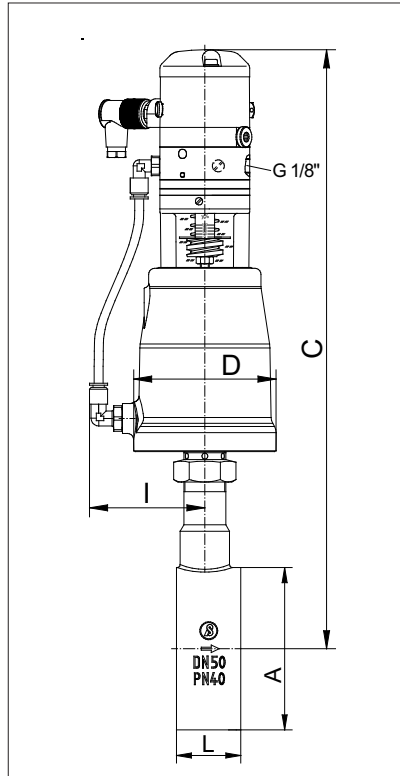

Type 8044 with i/p-positioner
Type 8047
with positioner indicator

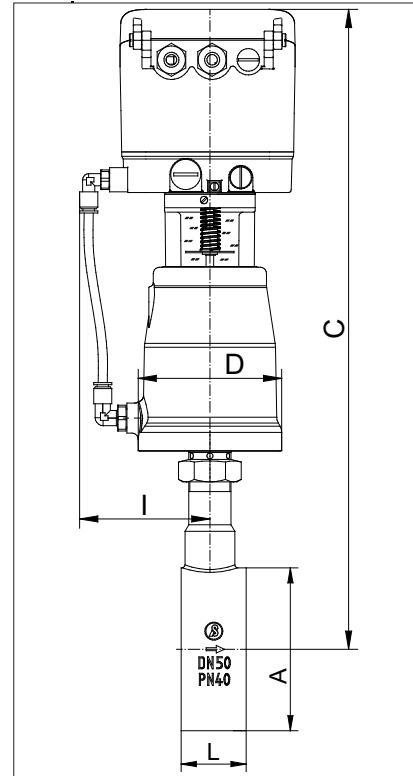

Type 8044 with digital positioner
Type 8049
with position indicator

DN	Actuator Ø	A	L	D	I	C carbon steel			C stainless steel body			Stroke H	Weight (kg)
						p/p positioner	i/p positioner	digital positioner	p/p positioner	i/p positioner	digital positioner		
15	80	53	33	96	80	349	381	406	236	358	383	6	4,9
15	125	53	33	146	105	369	401	426	346	378	403	6	6,7
20	80	62	33	96	80	354	386	411	331	363	388	6	5
20	125	62	33	146	105	374	406	431	351	383	408	6	6,8
25	80	72	33	96	80	359	391	415	336	368	393	6	5,1
25	125	72	33	146	105	379	411	436	356	388	413	6	6,9
32	80	82	33	96	80	362	394	419	340	372	397	6	5,1
32	125	82	33	146	105	382	414	439	360	392	417	6	6,9
40	80	92	33	96	80	367	399	424	345	377	402	6	5,3
40	125	92	33	146	105	387	419	444	365	402	422	6	7,1
50	80	108	43	96	80	368	400	425	368	400	425	8	6,4
50	125	108	43	146	105	388	420	445	388	420	445	8	8,2
65	80	126	46	96	80	377	409	434	377	409	434	8	6,9
65	125	126	46	146	105	397	429	454	397	429	454	8	8,7
80	80	142	46	96	80	385	417	442	385	417	442	8	7,6
80	125	142	46	146	105	405	427	462	405	427	462	8	9,4
100	80	164	52	96	80	398	430	455	398	430	455	8,5	8,8
100	125	164	52	146	105	418	450	475	418	450	475	8,5	10,6

Dimension C „reduced design“ shortened by 25,4 mm

Dimensions in mm