

ARTICULO: 2250
Mirilla de Turbulencia extremos Bridados.
Flanged ends Sight Glass.

Características

1. Mirilla de Turbulencia.
2. Extremos bridados según DIN 2501 PN 16.
3. Longitud entre caras según DIN 3202 F1.
4. Construcción en Acero Inox CF8M.
5. Presión de trabajo máxima 10 / 16 Kg / cm².
6. Temperatura de trabajo máxima 240 °C a 10 Kg/cm².

Features

1. *Sight Glass.*
2. *Flanges ends according to DIN 2501 PN 16.*
3. *Face to Face according to DIN 3202 F1.*
4. *Made of Stainless Steel CF8M.*
5. *Max. Working pressure 10 / 16 Kg / cm².*
6. *Max. Working temperature 240 °C at 10 Kg/cm²*

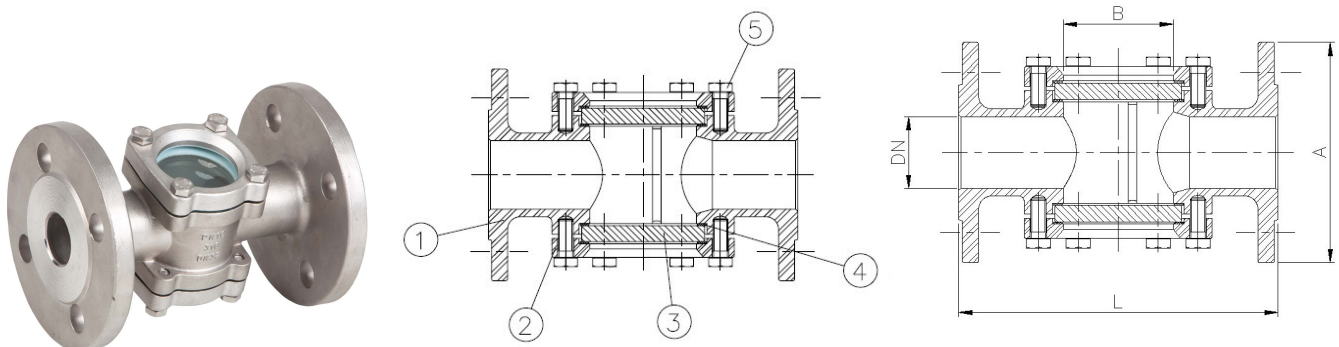

Nº	Denominación/Name	Material	Acabado Superficial/Surface Treatment
1	Cuerpo / Body	Acero Inox CF8M / Stainless Steel CF8M	Granallado / Shot Blasting + Pickling
2	Tapa / Cover	Acero Inox CF8M / Stainless Steel CF8M	Granallado / Shot Blasting + Pickling
3	Cristal / Glass	Vidrio Templado / Tempered Glass	-----
4	Junta / Gasket	Teflón / PTFE	-----
5	Tornillo / Bolt	Acero Inox 304 / Stainless Steel 304	-----

DIMENSIONES GENERALES / GENERAL DIMENSIONS

Ref	Medida/Size	PN	Dimensiones/Dimensions (mm)				Cristal / Glass	Peso/Weight (Kg)
			DN	L	A	B		
2250 04	1/2"	16	15	130	95	40	50 x 8	2.250
2250 05	3/4"	16	20	150	105	40	50 x 8	2.800
2250 06	1"	16	25	160	115	50	63 x 10	3.650
2250 07	1 1/4"	16	32	180	140	50	63 x 10	5.750
2250 08	1 1/2"	16	40	200	150	65	80 x 12	8.300
2250 09	2"	16	50	230	165	65	80 x 12	9.800
2250 10	2 1/2"	16	65	290	185	100	115 x 15	13.700
2250 11	3"	16	80	310	200	100	115 x 15	16.650
2250 12	4"	16	100	350	220	125	145 x 15	23.800

CURVA PRESION TEMPERATURA / PRESSURE TEMPERATURE RATING

